



EXAM PAPER MAKER
Your Ultimate Past Papers Hub

YEARLY PAST PAPERS WITH TOPICAL QUESTIONS TRACKER

Cambridge IGCSE

Physics (0625) Paper 1

[Multiple Choice (Core)]

SAMPLE EDITION
2020 QUESTION PAPERS & MARK SCHEMES

Note:

Provided for preview purposes to demonstrate format, organisation, and content quality. The full edition contains all examination years listed. For more information, visit:

[Cambridge IGCSE Physics \(0625\) Product Page](#)

Introduction

Topical Questions Tracker: An Efficient Study Tool

A Topical Questions Tracker is a powerful tool, integrated as an appendix to Yearly Past Papers, enhancing the functionality of utilising Past Papers. This tool allows you to locate specific questions by topic, providing a much more efficient way to study for exams.

How the Topical Questions Tracker Works

The Topical Questions Tracker is organized according to the latest syllabus of the subject. Each topic includes a comprehensive list of all relevant questions from the yearly past papers. For each question, the tracker provides:

- The paper's code
- The question number
- The sub-question number (if applicable)
- The page number where the question is located, which is hyperlinked for easy navigation

By clicking on the linked page number, you can jump directly to the corresponding page in the document, making it quick and simple to find the exact question you're looking for.

Advantages of Topical Questions Trackers Over Traditional Past Papers

While traditional Topical Past Papers classify entire questions under a single topic, many questions contain sub-questions that may cover different topics. This can make it difficult to find specific practice material for a particular area of study.

The Topical Questions Tracker overcomes this limitation by categorizing each sub-question individually. This precise classification ensures that each part of the question is assigned to the appropriate topic, providing a more targeted and effective revision tool.

Efficient Navigation Tips

While the Topical Questions Tracker allows you to jump directly to specific questions by clicking on the linked page numbers, navigating back to the previous page to find the next question can be time-consuming and somewhat frustrating. To streamline this process, you can utilize the 'Previous View' and 'Next View' commands in Adobe Reader.

To access these commands, navigate to the menu and select View » Go to » Previous View or Next View. Alternatively, you can use the shortcut keys for quicker navigation:

- Previous View: ALT + Left Arrow
- Next View: ALT + Right Arrow

These commands enable you to seamlessly move back and forth between the last two pages visited, enhancing your study efficiency by minimizing unnecessary navigation steps.

Contents

1	2020 Feb/Mar Variant 2 0625_m20_qp_12	3
1.1	2020 Feb/Mar Variant 2 0625_m20_ms_12	24
2	2020 May/June Variant 1 0625_s20_qp_11	28
2.1	2020 May/June Variant 1 0625_s20_ms_11	49
3	2020 May/June Variant 2 0625_s20_qp_12	53
3.1	2020 May/June Variant 2 0625_s20_ms_12	74
4	2020 May/June Variant 3 0625_s20_qp_13	78
4.1	2020 May/June Variant 3 0625_s20_ms_13	99
5	2020 Oct/Nov Variant 1 0625_w20_qp_11	103
5.1	2020 Oct/Nov Variant 1 0625_w20_ms_11	120
6	2020 Oct/Nov Variant 2 0625_w20_qp_12	124
6.1	2020 Oct/Nov Variant 2 0625_w20_ms_12	141
7	2020 Oct/Nov Variant 3 0625_w20_qp_13	145
7.1	2020 Oct/Nov Variant 3 0625_w20_ms_13	162
A	Topical Questions Tracker	166
A.1	Motion, forces and energy	166
A.1.1	Physical quantities and measurement techniques	166
A.1.2	Motion	166
A.1.3	Mass and weight	166
A.1.4	Density	166
A.1.5	Forces	167
A.1.6	Energy, work and power	167
A.1.7	Pressure	167
A.2	Thermal physics	168
A.2.1	Kinetic particle model of matter	168
A.2.2	Thermal properties and temperature	168
A.2.3	Transfer of thermal energy	168
A.3	Waves	169
A.3.1	General properties of waves	169
A.3.2	Light	169
A.3.3	Electromagnetic spectrum	169
A.3.4	Sound	170
A.4	Electricity and magnetism	170
A.4.1	Simple phenomena of magnetism	170
A.4.2	Electrical quantities	170
A.4.3	Electric circuits	170
A.4.4	Electrical safety	171
A.4.5	Electromagnetic effects	171
A.5	Nuclear physics	171
A.5.1	The nuclear model of the atom	171
A.5.2	Radioactivity	172



Cambridge IGCSE™

PHYSICS

0625/12

Paper 1 Multiple Choice (Core)

February/March 2020

45 minutes

You must answer on the multiple choice answer sheet.

You will need: Multiple choice answer sheet
Soft clean eraser
Soft pencil (type B or HB is recommended)

INSTRUCTIONS

- There are **forty** questions on this paper. Answer **all** questions.
- For each question there are four possible answers **A, B, C** and **D**. Choose the **one** you consider correct and record your choice in soft pencil on the multiple choice answer sheet.
- Follow the instructions on the multiple choice answer sheet.
- Write in soft pencil.
- Write your name, centre number and candidate number on the multiple choice answer sheet in the spaces provided unless this has been done for you.
- Do **not** use correction fluid.
- Do **not** write on any bar codes.
- You may use a calculator.
- Take the weight of 1.0 kg to be 10 N (acceleration of free fall = 10 m/s^2).

INFORMATION

- The total mark for this paper is 40.
- Each correct answer will score one mark. A mark will not be deducted for a wrong answer.
- Any rough working should be done on this question paper.

This document has **20** pages. Blank pages are indicated.



- 1 The diagram shows a rectangular metal sheet close to two rulers.

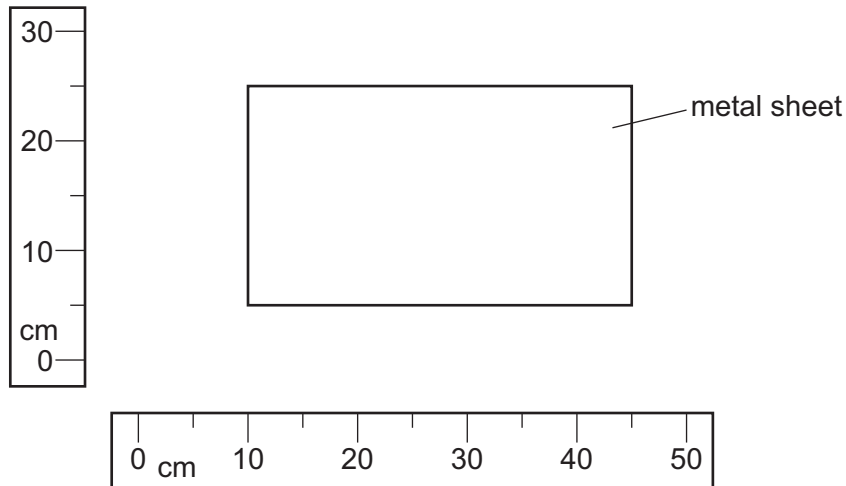

What is the area of the metal sheet?

- A** 700 cm^2 **B** 875 cm^2 **C** 900 cm^2 **D** 1125 cm^2
- 2 The graph shows how the speed of a car changes with time over part of a journey.

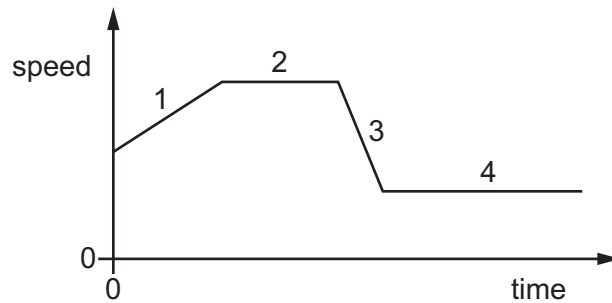

Which section of the graph shows acceleration and which section of the graph shows deceleration?

	acceleration	deceleration
A	1	2
B	1	3
C	2	4
D	3	1

- 3 A steel ball is dropped from the top floor of a building. Air resistance can be ignored.

Which statement describes the motion of the ball?

- A The ball falls with constant acceleration.
 B The ball falls with constant speed.
 C The ball falls with decreasing speed.
 D The ball falls with increasing acceleration.
- 4 Diagram 1 shows a piece of flexible material that contains many pockets of air. Diagram 2 shows the same piece of flexible material after it has been compressed so that its volume decreases.

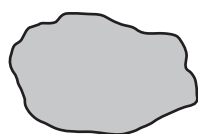

diagram 1
(before compression)

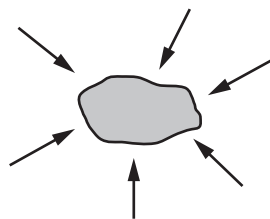

diagram 2
(after compression)

What happens to the mass and to the weight of the flexible material when it is compressed?

	mass	weight
A	increases	increases
B	increases	no change
C	no change	increases
D	no change	no change

- 5 On the Moon, the gravitational field strength g is 1.6 N/kg .

An object has a mass of 2.0 kg .

What is the weight of the object on the Moon?

- A 0 N B 1.3 N C 3.2 N D 20.0 N
- 6 A measuring cylinder contains 40 cm^3 of water.
 A solid metal ball is dropped into the water and the water level rises to 56 cm^3 .
 The mass of the ball is 80 g .
 What is the density of the metal from which the ball is made?
- A 0.20 g/cm^3 B 1.4 g/cm^3 C 2.0 g/cm^3 D 5.0 g/cm^3

- 7 A car travels along a horizontal road at constant speed. Three horizontal forces act on the car. The diagram shows two of these forces.

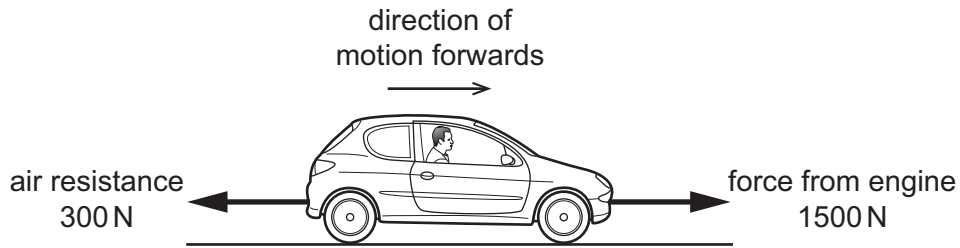

What is the size and the direction of the third horizontal force acting on the car?

- A 1200 N backwards
 - B 1200 N forwards
 - C 1800 N backwards
 - D 1800 N forwards
- 8 A force F is applied to a spanner, as shown.

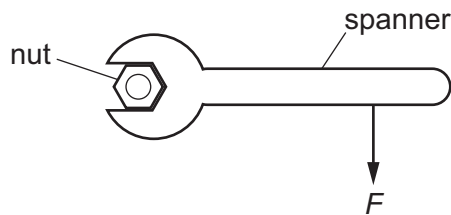

Which action increases the moment of F about the centre of the nut?

- A apply the force F to the end of the spanner handle
 - B apply the force F parallel to the spanner handle
 - C spray oil on the nut
 - D use a shorter spanner
- 9 A ball is released from rest and rolls down a track from the position shown.
- What is the furthest position that it is possible for the ball to reach?

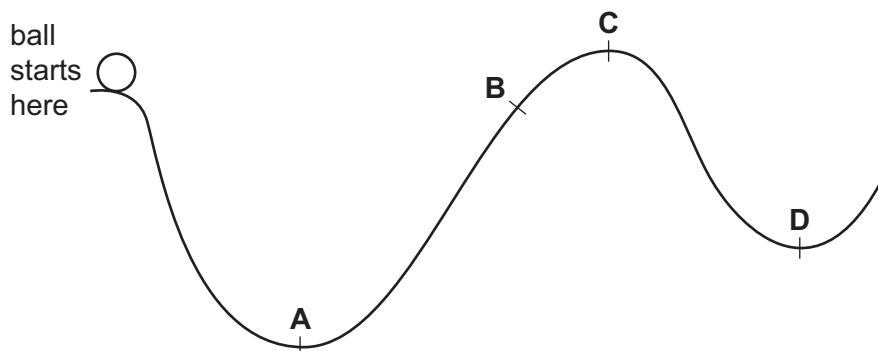

10 Which row describes an advantage and a disadvantage of wind turbines?

	advantage	disadvantage
A	no fuel needed	harmful gases released
B	variable supply	fuel needed
C	no harmful gases released	variable supply
D	constant supply	noisy

11 A box of mass m and weight W is carried up some stairs of total height x and total width y .

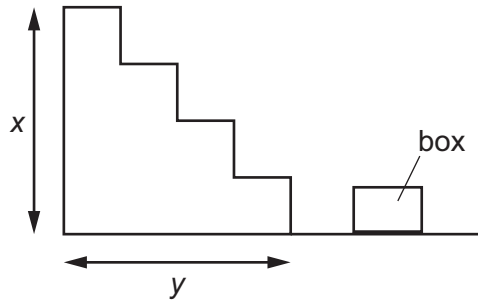

On which quantities does the work done against gravity on the box depend?

- A** m and y **B** W and x **C** W and y **D** x and y

- 12 Diagram 1 shows a tube sealed at one end and partly immersed in mercury. The tube has a diameter d . The top of the mercury in the tube is a height h above the mercury reservoir.

diagram 1

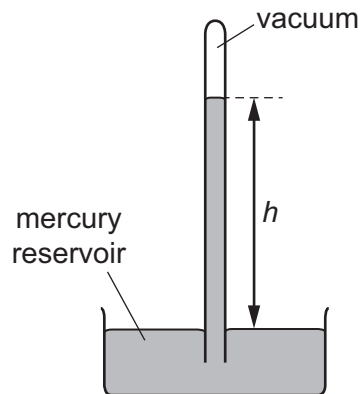
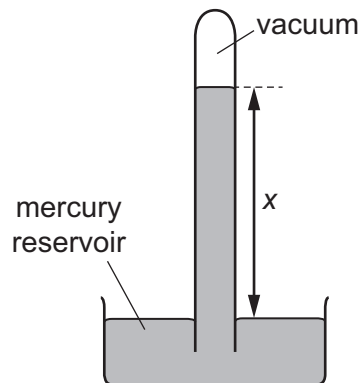

Diagram 2 shows a similar arrangement with a tube that has a diameter $2d$.

diagram 2



What is the relationship between h and x ?

- A $x = 2h$
- B $x = h$
- C $x = \frac{h}{2}$
- D $x = \frac{h}{4}$

- 13 A skier is standing still on a flat area of snow.



The weight of the skier is 550 N. The total area of his skis in contact with the ground is 0.015 m^2 .

What is the pressure exerted on the ground by the skier?

- A 0.83 N/m^2 B 8.3 N/m^2 C 3700 N/m^2 D 37000 N/m^2
- 14 The molecules of a substance in a particular state of matter move freely with random motion. The average speed of the molecules is increasing.

What is being described?

- A a gas being heated
 B a liquid evaporating
 C a solid being heated
 D a solid melting
- 15 A student measures the mass of warm water in an open container over two minutes. The container is kept at a constant temperature. The results are in the table.

time / minutes	mass / g
0.0	33.9
0.5	30.6
1.0	27.6
1.5	24.9
2.0	22.5

Why does the mass of the water change?

- A The water evaporates.
 B The water freezes.
 C The water condenses.
 D The water boils.

16 Which points are the fixed points of the liquid-in-glass thermometer shown?

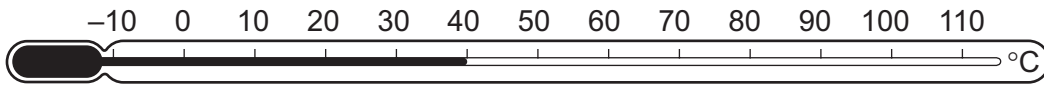

- A the beginning and end points of the column of liquid
- B the points marked -10°C and 110°C
- C the points marked 0°C and 100°C
- D the top and bottom points of the thermometer bulb

17 Four different metal blocks are given the same quantity of thermal energy.

Which block has the greatest thermal capacity?

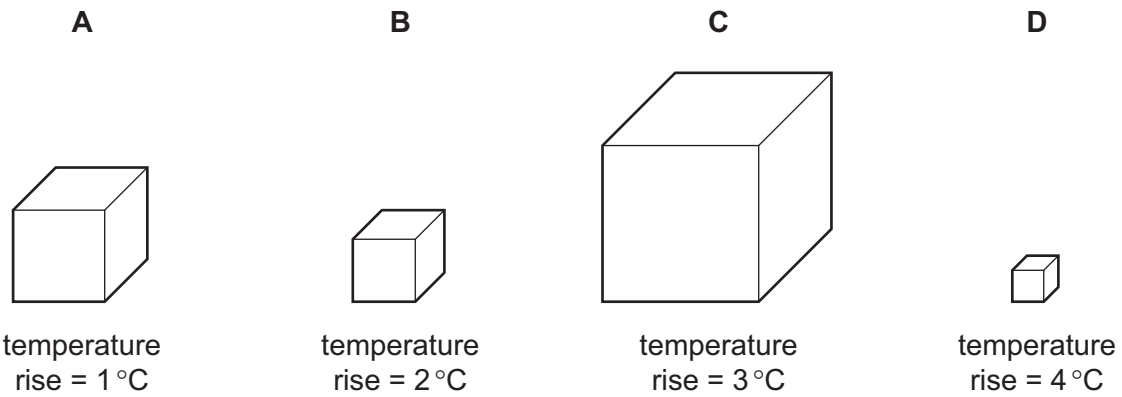

18 A solid is heated from room temperature.

The graph shows how its temperature changes with time as it is heated constantly.

At which time has it just become completely liquid?

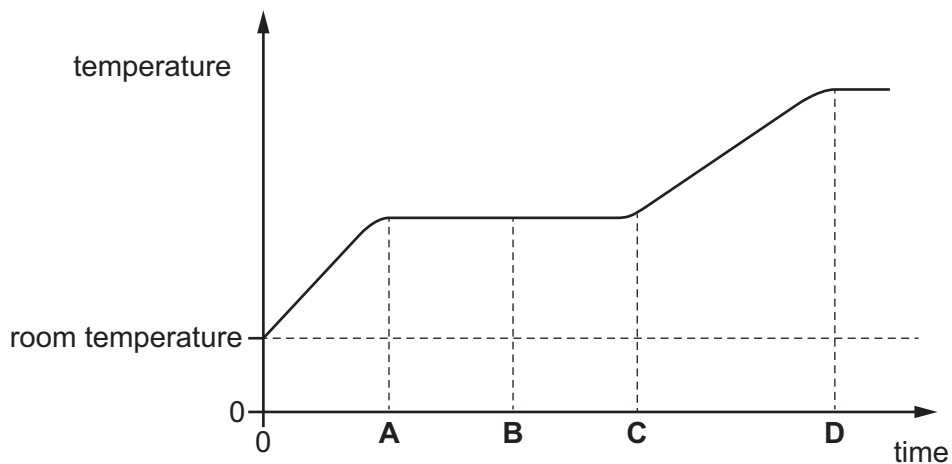

- 19 Rods of the same shape and size are inserted through corks into a tank of hot water. Each rod is covered with a layer of solid wax that has a low melting point. After a period of time, some wax melts.

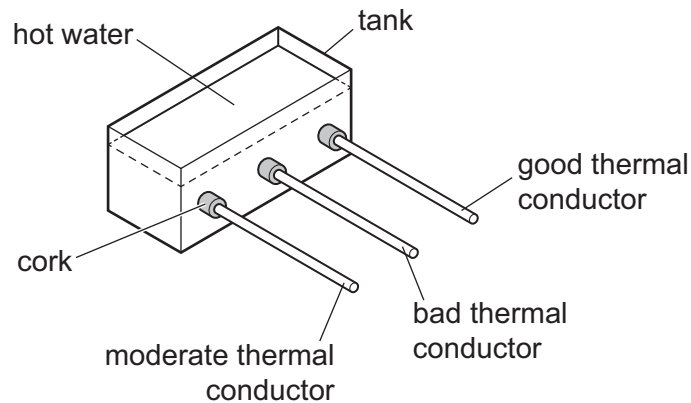

On which rod will the wax melt first?

- A all at the same time
 - B good thermal conductor
 - C bad thermal conductor
 - D moderate thermal conductor
- 20 A boy jumps into an indoor swimming pool. He notices that the water appears to get colder as he goes deeper underwater. This is due to convection.
- Which statement is correct?
- A Cold water is more dense than warm water so it sinks to the bottom of the pool.
 - B Warm water is more dense than cold water so it rises to the surface of the pool.
 - C The molecules in cold water have more kinetic energy than the molecules in warm water so they move to the bottom of the pool faster.
 - D The molecules in warm water are closer together than the molecules in cold water so they rise to the surface of the pool.

21 The diagrams show examples of wave motion.

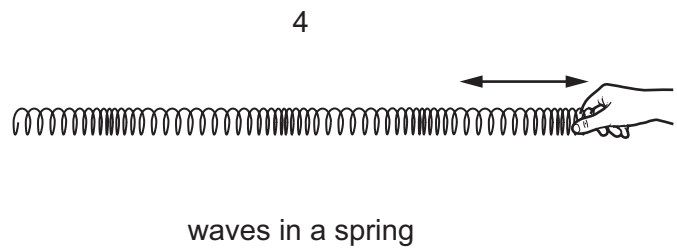
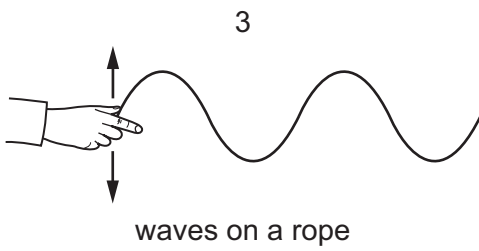
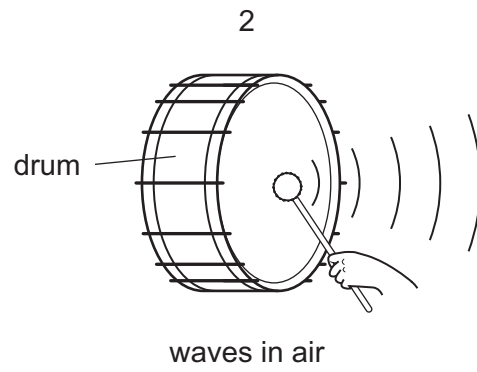
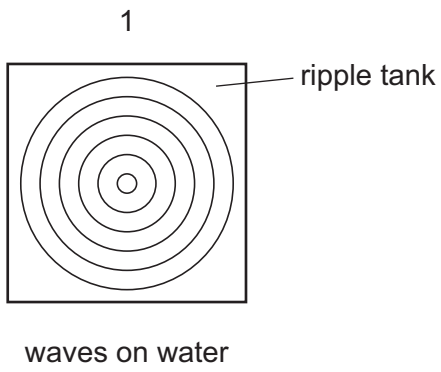

Which waves are longitudinal?

- A** 1 only **B** 2 and 3 only **C** 2, 3 and 4 **D** 2 and 4 only

22 Waves on the surface of water travel from deep to shallow water.

Which diagram shows the correct path of the waves in the shallow water?

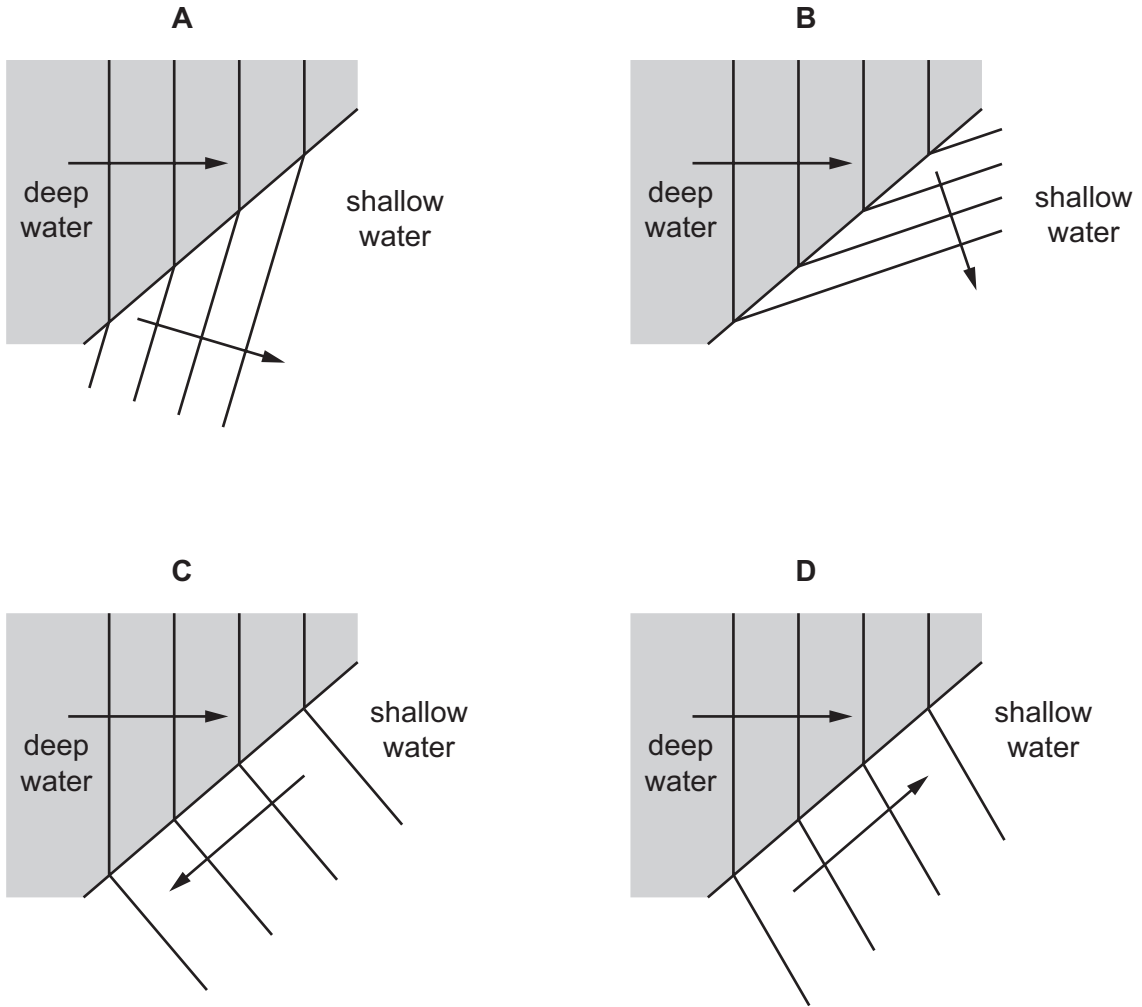

23 Which diagram shows how the light from a candle is reflected by a mirror, and shows the position of the image formed?

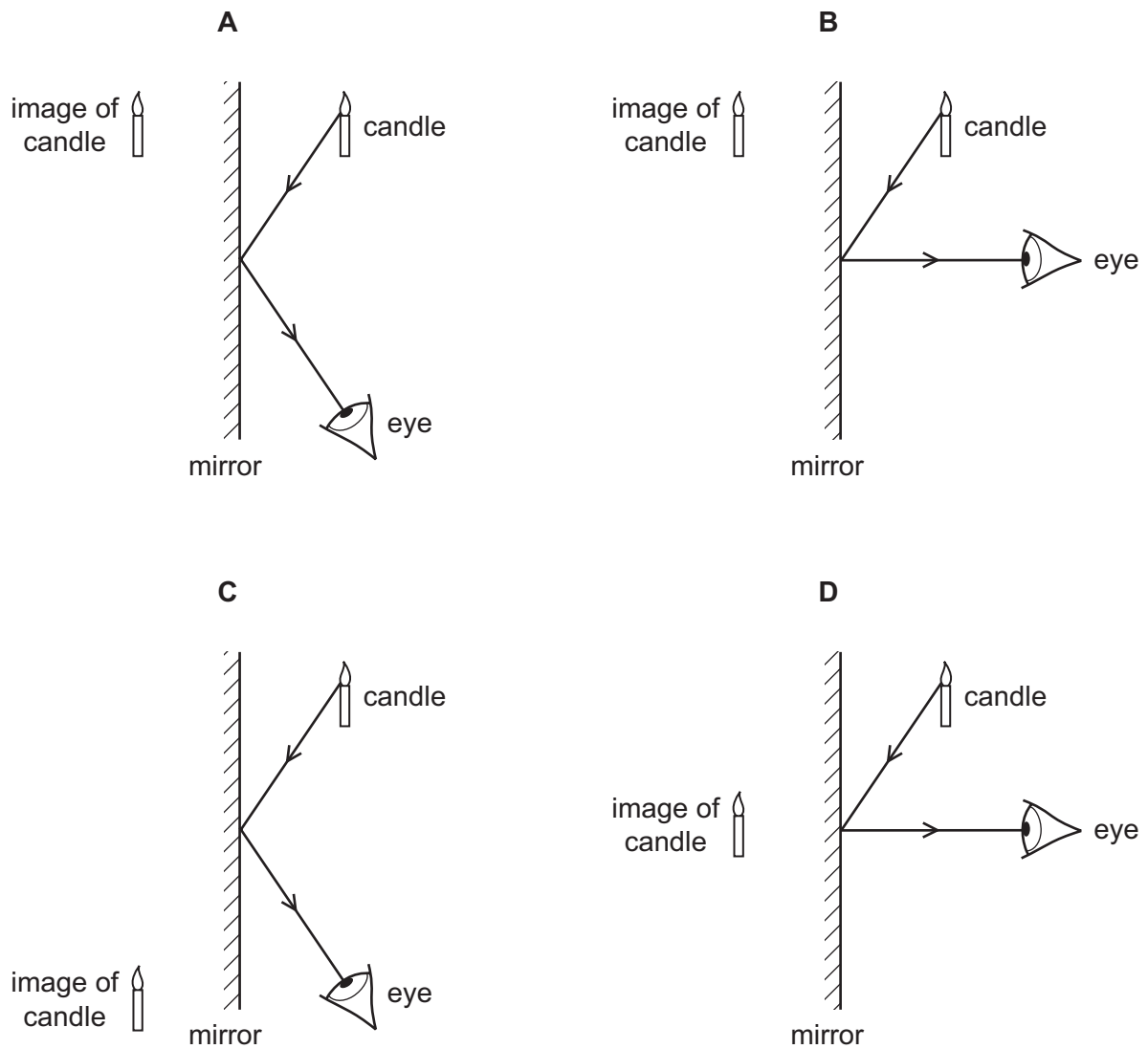

- 24 The diagram shows an image being formed by a converging lens.

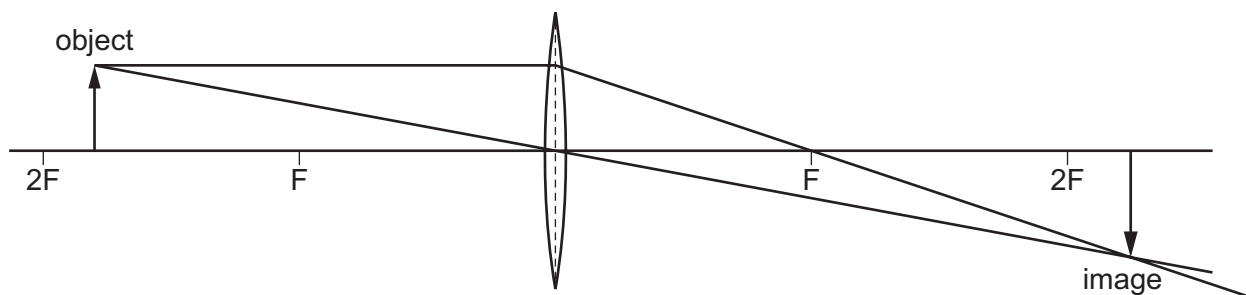

Which description of the image formed is correct?

- A** enlarged and inverted
B enlarged and upright
C diminished and inverted
D diminished and upright
- 25 The horn on a ship makes a sound. The captain on the ship hears an echo from a cliff 4.0 s later.

The speed of sound is 340 m/s.

How far away is the cliff from the ship?

- A** 170 m **B** 340 m **C** 680 m **D** 1360 m
- 26 Bats produce ultrasound waves to navigate.

What is a possible frequency range for these waves?

- A** 0–20 Hz
B 20 Hz–2000 Hz
C 2 kHz–20 kHz
D 20 kHz–120 kHz
- 27 The table shows the forces that exist between magnetic poles.

Which row is correct?

	N pole and N pole	N pole and S pole
A	attraction	attraction
B	attraction	repulsion
C	repulsion	attraction
D	repulsion	repulsion

28 The diagrams show three different metal rods P, Q and R, inside coils of wire.

Small iron nails are placed on a wooden bench under the rods.

Diagram 1 shows the situation when there are electric currents in the wires.

Diagram 2 shows the situation when the currents are switched off.

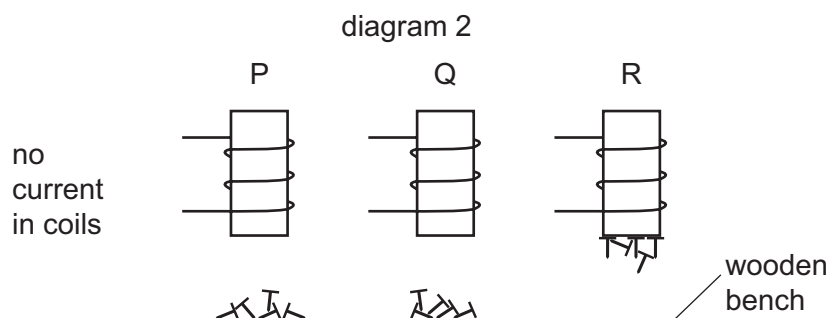
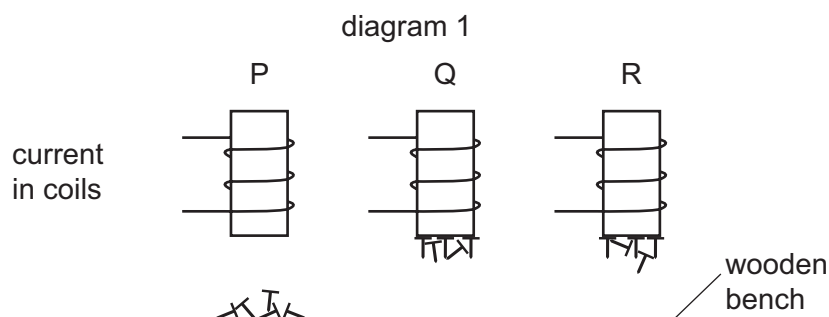

Which row correctly identifies the metal rods?

	P	Q	R
A	copper	soft iron	steel
B	soft iron	copper	steel
C	steel	soft iron	copper
D	copper	steel	soft iron

29 A polythene rod becomes negatively charged when it is rubbed with a cloth.

Which statement explains this?

- A** The rod gains electrons.
- B** The rod loses electrons.
- C** The rod gains protons.
- D** The rod loses protons.

30 The diagram shows a reading on an ammeter.

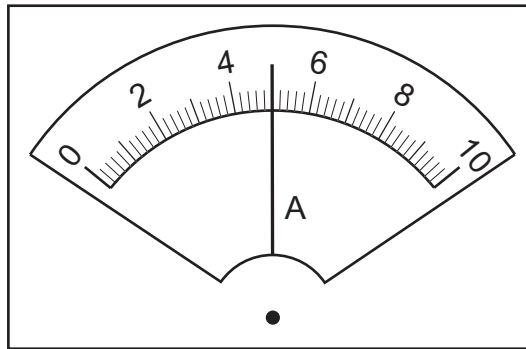

What is the reading?

- A** 0.45A **B** 0.50A **C** 4.5A **D** 5.0A

31 A student is to determine the resistance of resistor R. She uses a circuit including a voltmeter and an ammeter.

Which circuit should be used?

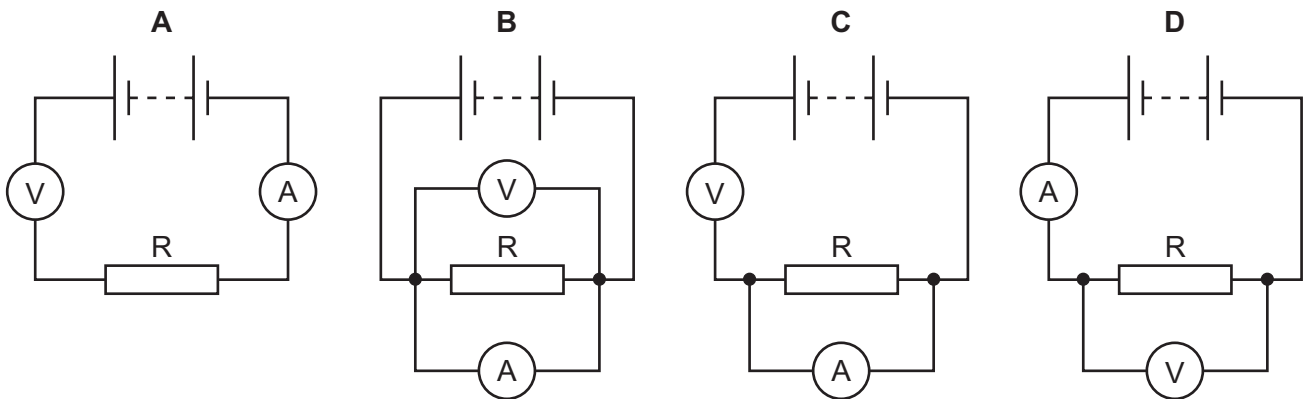

- 32 The diagram shows a battery connected to two resistors. Three ammeters M_1 , M_2 and M_3 are connected in the circuit.

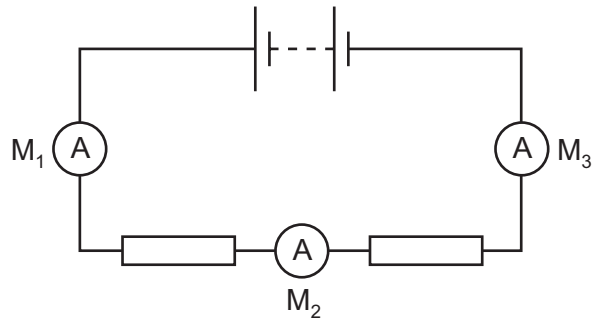

Ammeter M_1 reads 1.0 A.

What are the readings on M_2 and on M_3 ?

	reading on M_2/A	reading on M_3/A
A	0.0	0.0
B	0.5	0.5
C	0.5	1.0
D	1.0	1.0

- 33 Lamps in a circuit are connected in parallel.

What is the advantage of this?

- A** If one lamp breaks, the others remain lit.
- B** Less current is taken from the power supply.
- C** The lamps use less power than if they were connected in series.
- D** The potential difference across each lamp is less than that of the power supply.

34 The diagram shows a relay being used to control a buzzer.

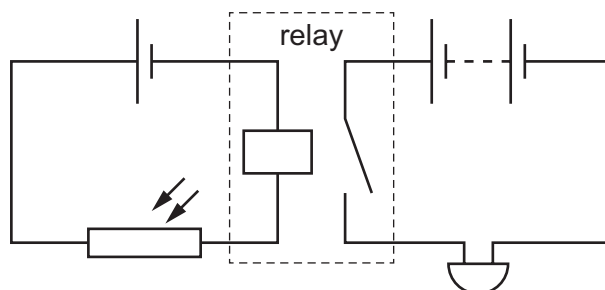

What is the function of the circuit?

- A The buzzer switches off when the circuit becomes cold.
- B The buzzer switches off when the circuit becomes light.
- C The buzzer switches on when the circuit becomes cold.
- D The buzzer switches on when the circuit becomes light.

35 There is a 5 A fuse in the circuit of an appliance.

What is the purpose of the fuse and in which wire is it connected?

	purpose	wire in which it is connected
A	breaks the circuit if the current is greater than 5 A	earth
B	breaks the circuit if the current is greater than 5 A	live
C	breaks the circuit if the current is less than 5 A	earth
D	breaks the circuit if the current is less than 5 A	live

36 The diagram shows a transformer that has an output voltage of 12 V.

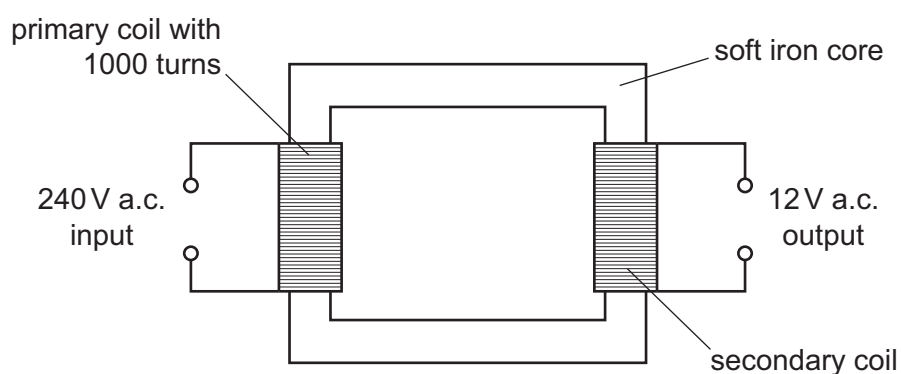

How many turns of wire are in the secondary coil?

- A 12
- B 20
- C 50
- D 20 000

- 37 A current-carrying conductor is placed between two magnetic poles. The current causes a force to act on the wire.

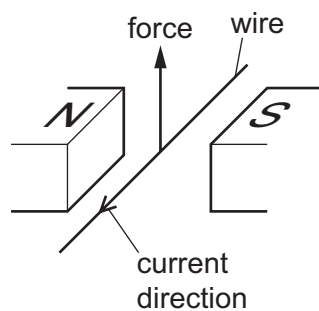

Three other arrangements P, Q and R, of the wire and magnetic poles are set up as shown.

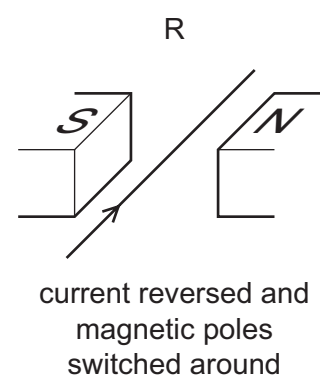
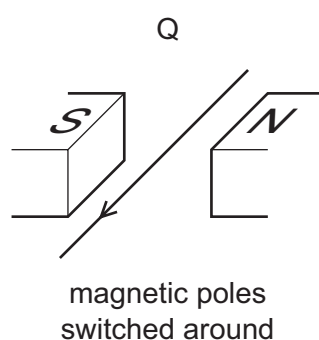
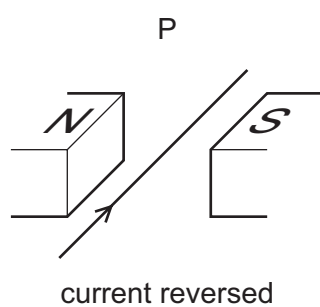

Which arrangements will cause a force in the opposite direction to that shown in the top diagram?

- A** P, Q and R **B** P and Q only **C** P only **D** R only
- 38 The symbol for a radioactive nuclide of carbon is ${}^{14}_6\text{C}$.

How many neutrons are in its nucleus?

- A** 6 **B** 8 **C** 14 **D** 20

- 39 A student measures the rate at which ionising radiation is emitted from a radioactive substance. He places a detector at different distances from the radioactive source.

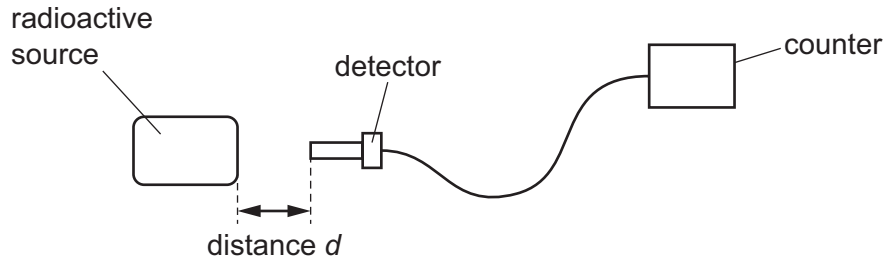

The table shows how the reading on the counter varies with distance d .

The readings on the counter are corrected for background radiation.

distance d /cm	0	2	4	6
counter reading / counts per minute	1250	115	0	0

Which type of ionising radiation is being emitted by the substance?

- A α -particles
- B β -particles
- C γ -rays
- D X-rays

40 The graph shows the count rate from a radioactive source over a period of time.

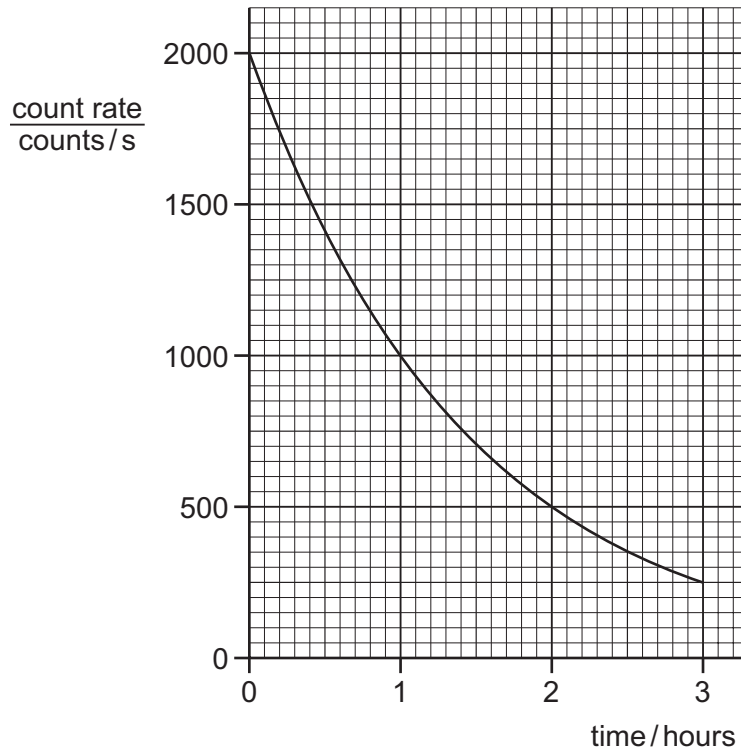

What is the half-life of the source?

- A** 0.5 hour **B** 1.0 hour **C** 1.5 hours **D** 3.0 hours

Permission to reproduce items where third-party owned material protected by copyright is included has been sought and cleared where possible. Every reasonable effort has been made by the publisher (UCLES) to trace copyright holders, but if any items requiring clearance have unwittingly been included, the publisher will be pleased to make amends at the earliest possible opportunity.

To avoid the issue of disclosure of answer-related information to candidates, all copyright acknowledgements are reproduced online in the Cambridge Assessment International Education Copyright Acknowledgements Booklet. This is produced for each series of examinations and is freely available to download at www.cambridgeinternational.org after the live examination series.

Cambridge Assessment International Education is part of the Cambridge Assessment Group. Cambridge Assessment is the brand name of the University of Cambridge Local Examinations Syndicate (UCLES), which itself is a department of the University of Cambridge.



Cambridge IGCSE™

PHYSICS

0625/12

Paper 1 Multiple Choice (Core)

March 2020

MARK SCHEME

Maximum Mark: 40

Published

This mark scheme is published as an aid to teachers and candidates, to indicate the requirements of the examination.

Mark schemes should be read in conjunction with the question paper and the Principal Examiner Report for Teachers.

Cambridge International will not enter into discussions about these mark schemes.

Cambridge International is publishing the mark schemes for the March 2020 series for most Cambridge IGCSE™, Cambridge International A and AS Level components and some Cambridge O Level components.

This document consists of **3** printed pages.

Question	Answer	Marks
1	A	1
2	B	1
3	A	1
4	D	1
5	C	1
6	D	1
7	A	1
8	A	1
9	B	1
10	C	1
11	B	1
12	B	1
13	D	1
14	A	1
15	A	1
16	C	1
17	A	1
18	C	1
19	B	1
20	A	1
21	D	1
22	A	1
23	A	1
24	A	1
25	C	1
26	D	1
27	C	1
28	A	1

Question	Answer	Marks
29	A	1
30	D	1
31	D	1
32	D	1
33	A	1
34	D	1
35	B	1
36	C	1
37	B	1
38	B	1
39	A	1
40	B	1



Cambridge IGCSE™

PHYSICS

Paper 1 Multiple Choice (Core)

0625/11

May/June 2020

45 minutes

You must answer on the multiple choice answer sheet.

You will need: Multiple choice answer sheet
Soft clean eraser
Soft pencil (type B or HB is recommended)

INSTRUCTIONS

- There are **forty** questions on this paper. Answer **all** questions.
- For each question there are four possible answers **A, B, C** and **D**. Choose the **one** you consider correct and record your choice in soft pencil on the multiple choice answer sheet.
- Follow the instructions on the multiple choice answer sheet.
- Write in soft pencil.
- Write your name, centre number and candidate number on the multiple choice answer sheet in the spaces provided unless this has been done for you.
- Do **not** use correction fluid.
- Do **not** write on any bar codes.
- You may use a calculator.
- Take the weight of 1.0 kg to be 10 N (acceleration of free fall = 10 m/s^2).

INFORMATION

- The total mark for this paper is 40.
- Each correct answer will score one mark. A mark will not be deducted for a wrong answer.
- Any rough working should be done on this question paper.

This document has **20** pages. Blank pages are indicated.



- 1 A pendulum makes 50 complete swings in 2 min 40 s.

What is the time period for 1 complete swing?

- A 1.6 s B 3.2 s C 4.8 s D 6.4 s

- 2 The motion of an object is represented by the speed–time graph shown.

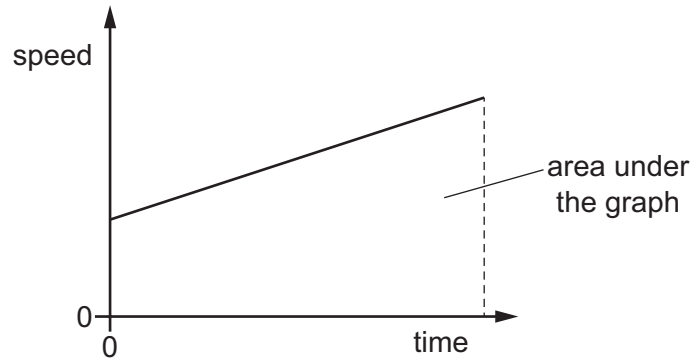

Which quantity is equal to the area under the graph?

- A acceleration
B average speed
C distance travelled
D kinetic energy
- 3 Which statement about acceleration is correct?
- A It is related to the changing speed of an object.
B It is the distance an object travels in one second.
C It is the force acting on an object divided by the distance it travels in one second.
D It is the force acting on an object when it is near to the Earth.

- 4 Two metal blocks P and Q have identical dimensions. They hang on identical spring balances.

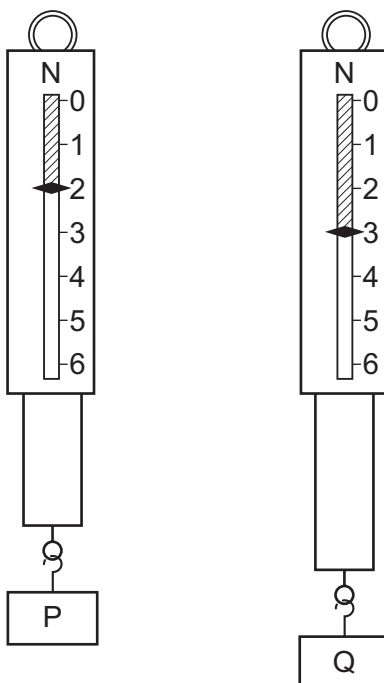

Which statement about P and Q is correct?

- A They have different volumes and different weights.
 - B They have different volumes and equal weights.
 - C They have equal volumes and equal weights.
 - D They have equal volumes and different weights.
- 5 A mass of 6.0 kg rests on the surface of a planet.

On this planet, $g = 20 \text{ N/kg}$.

What is the weight of the object?

- A 0.30 N B 0.60 N C 60 N D 120 N

- 6 The mass of a measuring cylinder is 190 g.

400 cm³ of liquid is put into the measuring cylinder.

The total mass of the measuring cylinder and the liquid is 560 g.

Four solid objects are lowered in turn into the liquid. The densities of the objects are shown.

- 1 0.40 g/cm³
- 2 0.90 g/cm³
- 3 1.2 g/cm³
- 4 2.7 g/cm³

Which objects will float in the liquid?

- A** 1 only **B** 1 and 2 only **C** 1, 2 and 3 **D** 3 and 4 only
- 7 A sledge is pulled in a straight line by dogs, as shown.

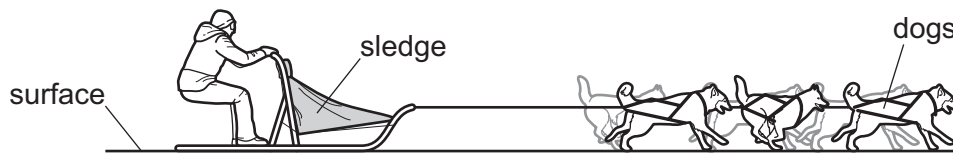

The dogs produce a total horizontal driving force of 600 N.

The frictional force between the sledge and the surface is 150 N and the air resistance on the sledge is 450 N.

What is the resultant force acting on the sledge?

- A** 0 N **B** 300 N **C** 900 N **D** 1200 N
- 8 Forces are applied to four identical objects.

The lengths of the arrows indicate the magnitude of each force.

Which object is in equilibrium?

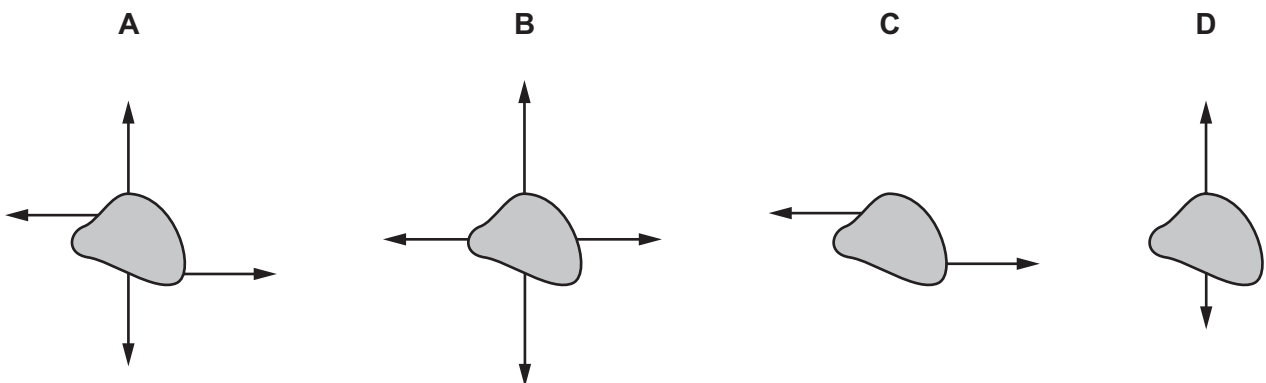

- 9 The diagram shows part of a rollercoaster ride with the car at different positions. The car runs freely down from position X to position Y and up the hill on the other side.

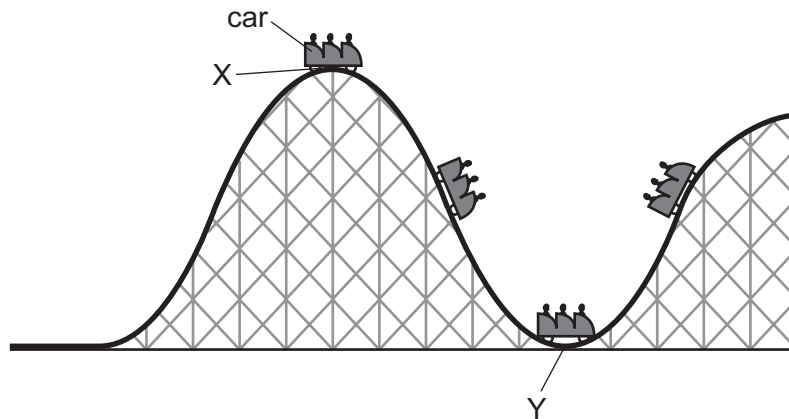

What happens to the kinetic energy and to the gravitational potential energy of the car as it moves from position X to position Y?

	kinetic energy	gravitational potential energy
A	decreases	decreases
B	decreases	increases
C	increases	decreases
D	increases	increases

- 10 Student P uses a force of 35 N to push a box 3.0 m across the floor. Student Q uses a force of 22 N to push another box 1.8 m across the floor. Which statement gives a full explanation why student P uses more energy than student Q?
- A** Student P pushes his box a greater distance than student Q.
- B** Student P pushes his box a greater distance and uses a bigger force than student Q.
- C** Student P uses a bigger force than student Q.
- D** Student P pushes a heavier box than student Q.

11 A man can either take an escalator or a lift to travel up between two floors in a hotel.

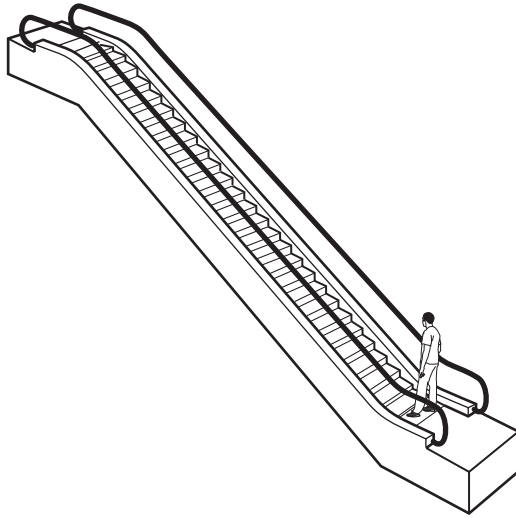

escalator

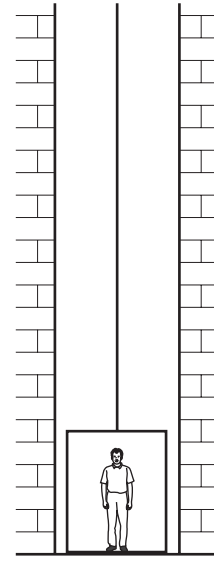

lift

The escalator takes 20 seconds to carry the man between the two floors. The useful work done against gravity is W . The useful power developed is P .

The lift takes 30 seconds to carry the same man between the same two floors.

How much useful work against gravity is done by the lift, and how much useful power is developed by the lift?

	useful work done against gravity by lift	useful power developed by lift
A	more than W	less than P
B	more than W	P
C	W	less than P
D	W	P

12 The diagram shows a solid block resting on a bench. The dimensions of the block are shown.

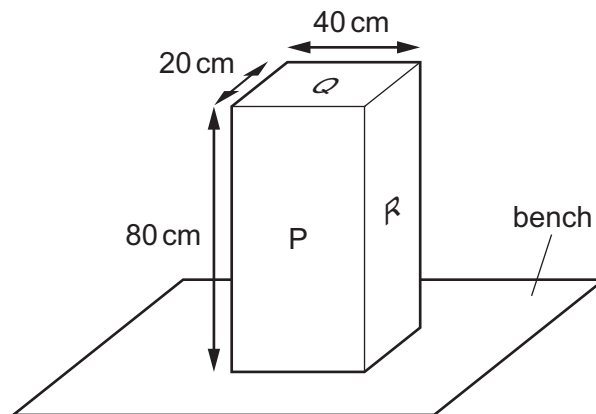

On which labelled surface should the block rest to produce the smallest pressure on the bench?

- A P
- B Q
- C R
- D P, Q and R produce the same pressure

- 13 Four submarines are submerged. The density of fresh water is 1000 kg/m^3 and the density of sea water is 1020 kg/m^3 .

Which submarine experiences the greatest pressure due to the water?

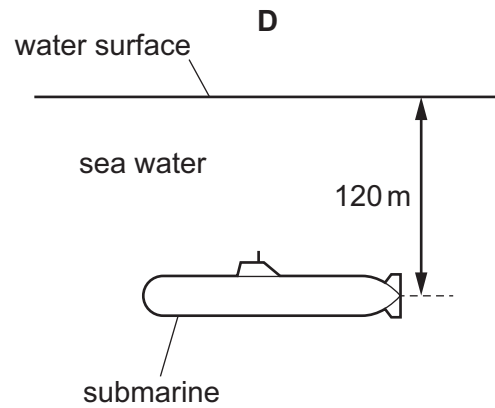
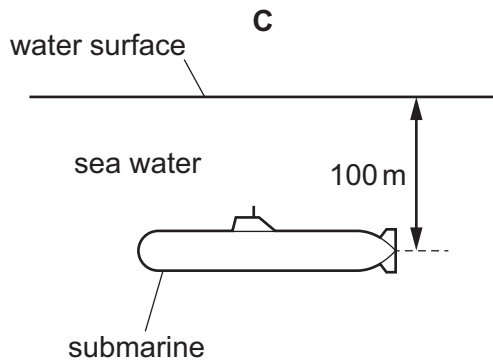
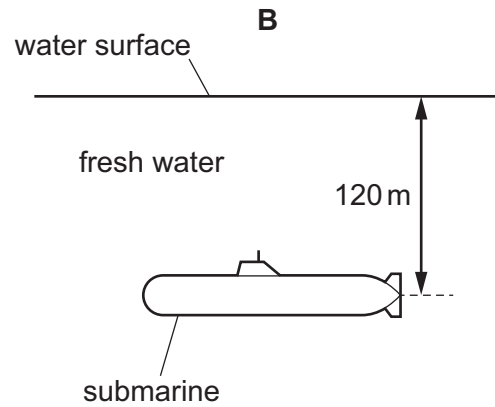
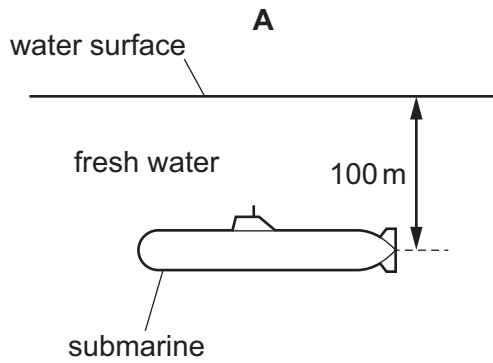

- 14 A gas is heated in a sealed container.

The volume of the container does not change.

What happens to the molecules of the gas?

- A** The average distance between molecules increases.
- B** The average kinetic energy of the molecules increases.
- C** The mass of each molecule increases.
- D** The volume of each molecule increases.

- 15 A student is investigating evaporation. She soaks a piece of cotton wool in a liquid and attaches this to the bulb of a thermometer.

As the liquid evaporates the temperature reading on the thermometer changes.



Which statement is correct?

- A** The more energetic molecules leave the liquid and the temperature reading decreases.
B The more energetic molecules leave the liquid and the temperature reading increases.
C The less energetic molecules leave the liquid and the temperature reading decreases.
D The less energetic molecules leave the liquid and the temperature reading increases.
- 16 The thermometer in the diagram has no scale.

Before this thermometer can be used to measure temperature, two standard temperatures known as fixed points are needed. These are labelled X and Y.

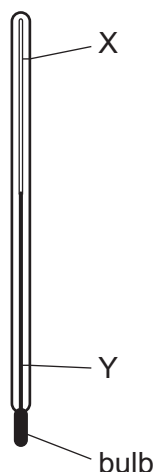

Which row describes these fixed points on the Celsius scale?

	X	Y
A	temperature of pure boiling water	normal body temperature
B	temperature of pure boiling water	temperature of pure melting ice
C	normal body temperature	temperature of pure boiling water
D	temperature of pure melting ice	temperature of pure boiling water

17 When a hot gas is left to cool, its internal energy decreases.

What causes this?

- A a decrease in the kinetic energy of the gas particles
- B a decrease in the gravitational potential energy of the gas particles
- C an increase in the average speed of the gas particles
- D an increase in the average distance of separation of the gas particles

18 The diagrams show four blocks of steel. The blocks are all drawn to the same scale.

The same quantity of thermal energy is given to each block.

Which block shows the greatest rise in temperature?

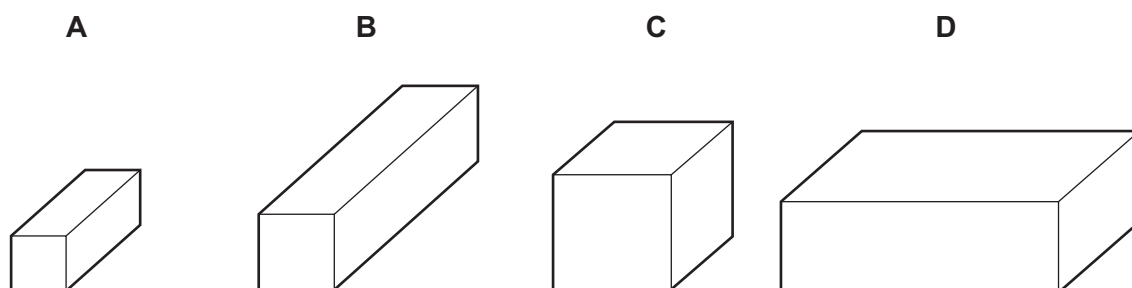

19 One ice cube is placed on a metal block. An identical ice cube is placed on a plastic block. The blocks are left next to each other on a table in a laboratory.

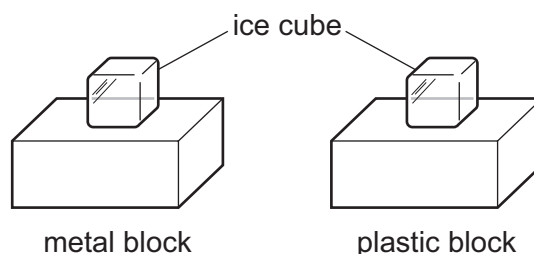

Which ice cube melts first and why?

- A The ice cube on the plastic block melts first because plastic is a good insulator of thermal energy.
- B The ice cube on the plastic block melts first because plastic is a good conductor of thermal energy.
- C The ice cube on the metal block melts first because metal is a good conductor of thermal energy.
- D The ice cube on the metal block melts first because metal is a good insulator of thermal energy.

- 20 Two freezers X and Y are identical except that one has a door opening at the front and the other has a door opening at the top.

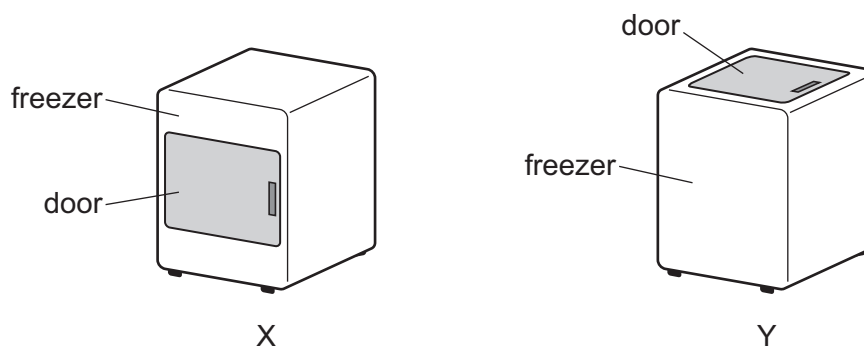

Both doors are the same size and are opened for the same amount of time.

Which freezer gains the least amount of thermal energy in this time and why?

	freezer gaining the least thermal energy	reason
A	X	cold air falls
B	X	warm air falls
C	Y	cold air falls
D	Y	warm air falls

- 21 The diagram shows a wave.

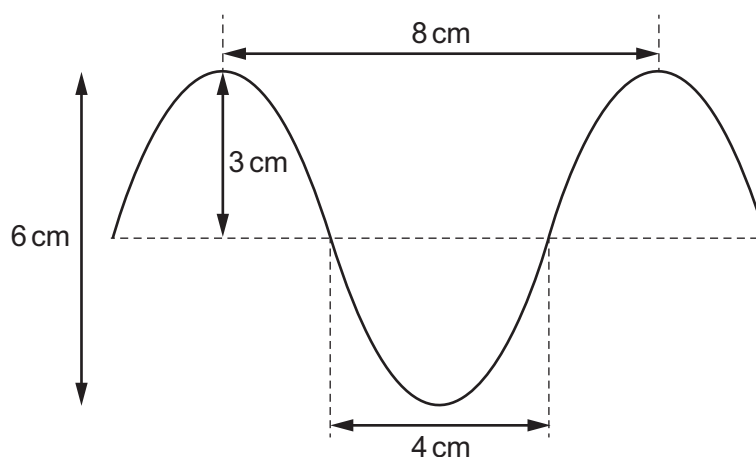

What are the amplitude and the wavelength of this wave?

	amplitude / cm	wavelength / cm
A	3	4
B	3	8
C	6	4
D	6	8

- 22 Waves travel more quickly on the surface of water when the water is deep.

A stone is dropped at point X into a pool of varying depth. The diagram shows the first three wavefronts on the surface of the pool.

The region between X and which labelled point is likely to be the deepest?

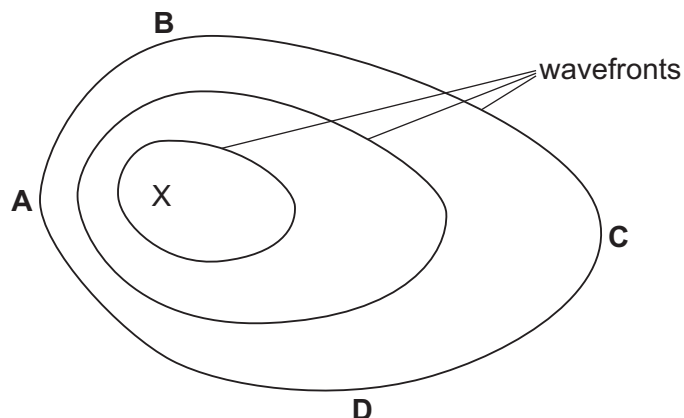

- 23 The diagram shows a beam of light travelling through glass and meeting a glass-air interface.

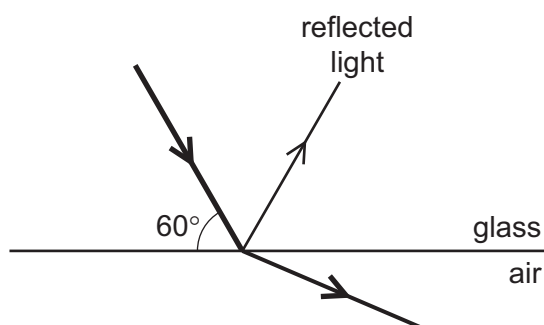

Which row correctly describes what is happening at the glass-air interface?

	angle of incidence at the interface	observation
A	30°	some internal reflection
B	30°	total internal reflection
C	60°	some internal reflection
D	60°	total internal reflection

24 A narrow beam of white light passes through a prism and is dispersed into a spectrum.

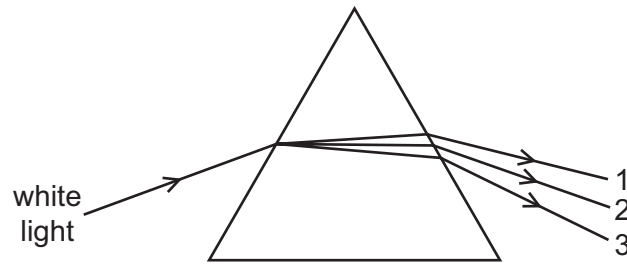

Which row is correct?

	colour 1	colour 2	colour 3
A	blue	yellow	red
B	red	blue	yellow
C	red	yellow	blue
D	yellow	blue	red

25 An intruder alarm sensor detects that a person is warmer than his surroundings.

Which type of electromagnetic wave does the sensor detect?

- A** infrared
- B** radio
- C** ultraviolet
- D** visible light

- 26 The graphs show the displacement of particles in sound waves from three sources X, Y and Z. The scales on the graphs are all identical.

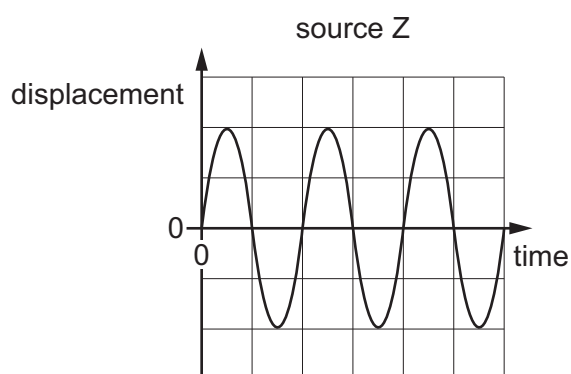
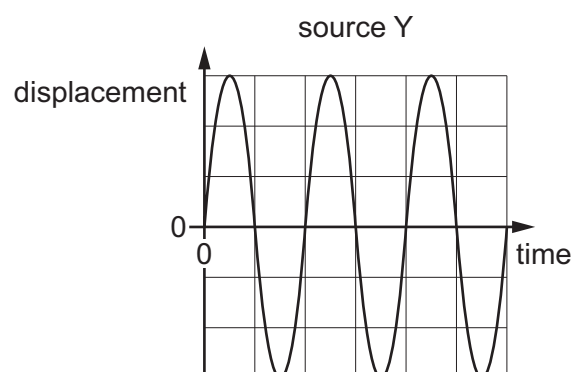
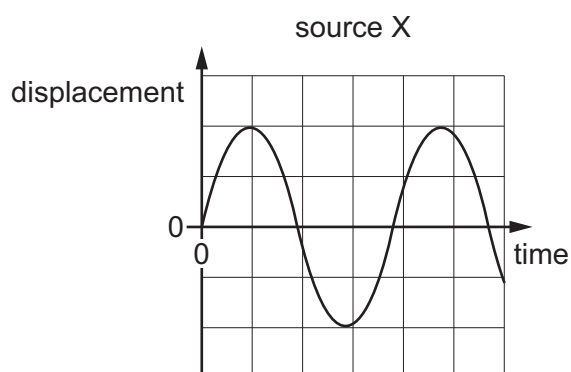

Which sources are producing sound waves with the same pitch?

- A** X and Y only **B** Y and Z only **C** X and Z only **D** X, Y and Z

- 27 A permanent magnet is to be made.

Which row gives the correct material to use and the correct reason for choosing this material?

	material	reason
A	soft iron	easy to demagnetise
B	soft iron	hard to demagnetise
C	steel	easy to demagnetise
D	steel	hard to demagnetise

28 Four nails **A**, **B**, **C** and **D** are tested to find which makes the strongest permanent magnet.

One of the nails is placed against a bar magnet and the number of paper clips which the nail can support is recorded.

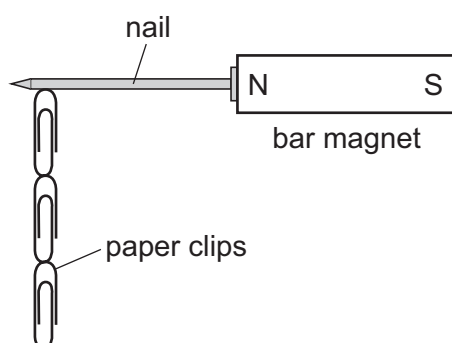

The bar magnet is then removed and the number of paper clips remaining attached to the nail is recorded. Each nail is tested individually.

Which nail becomes the strongest permanent magnet?

	number of paper clips attached to the nail	
	bar magnet present	bar magnet removed
A	2	0
B	2	1
C	4	3
D	5	2

29 Three statements about electric charge are given.

- 1 An ammeter directly measures how much electric charge is in an object.
- 2 A moving electric charge can be detected by an ammeter.
- 3 A flow of electric charge is an electric current.

Which statements are correct?

- A** 1 and 2 only **B** 1 and 3 only **C** 2 and 3 only **D** 1, 2 and 3

- 30 Each of the four diagrams M, N, O and P shows a separate pair of insulating rods. Each rod is charged as shown.

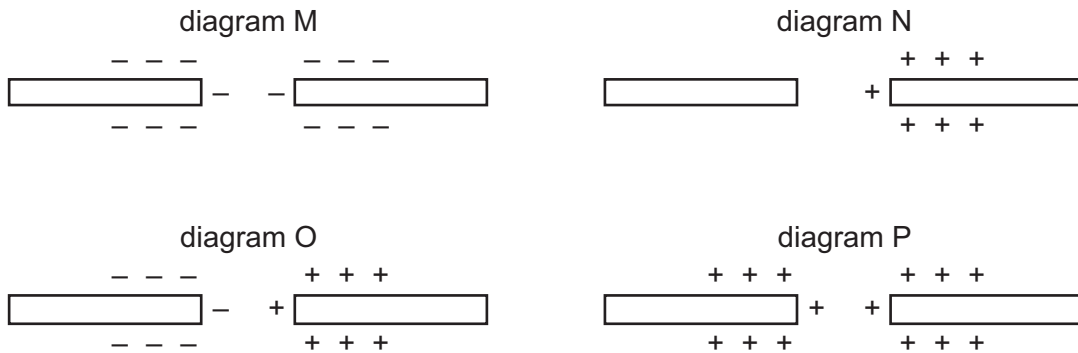

In which **two** arrangements do the pairs of rods experience a force of repulsion?

- A** M and N **B** O and P **C** M and P **D** N and O
- 31 A student uses the circuit shown to determine the resistance of two identical resistors.

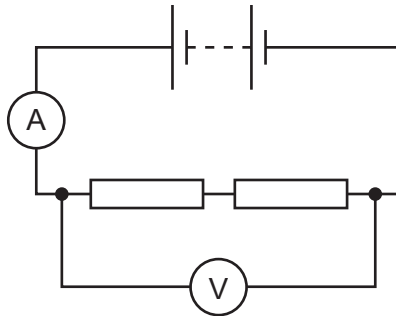

The voltmeter reading is 2.2 V and the ammeter reading is 0.25 A.

What is the resistance of each resistor?

- A** 0.275 Ω **B** 0.55 Ω **C** 4.4 Ω **D** 8.8 Ω

32 In the circuit shown, A_1 and A_2 are ammeters.

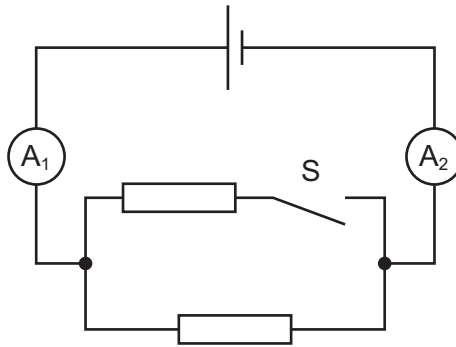

Switch S is closed.

Which row is correct?

	the resistance of the whole circuit	reading of A_1	reading of A_2
A	decreases	stays the same	increases
B	decreases	increases	increases
C	increases	stays the same	stays the same
D	increases	decreases	decreases

33 What happens to the resistance of an LDR when the brightness of light falling on it increases?

- A** Its resistance decreases.
- B** Its resistance increases.
- C** Its resistance increases then decreases.
- D** Its resistance stays the same.

34 A student constructs four circuits, each containing a fuse.

The fuse blows in one circuit and both lamps in the circuit go out.

In which circuit does the fuse blow and both lamps go out?

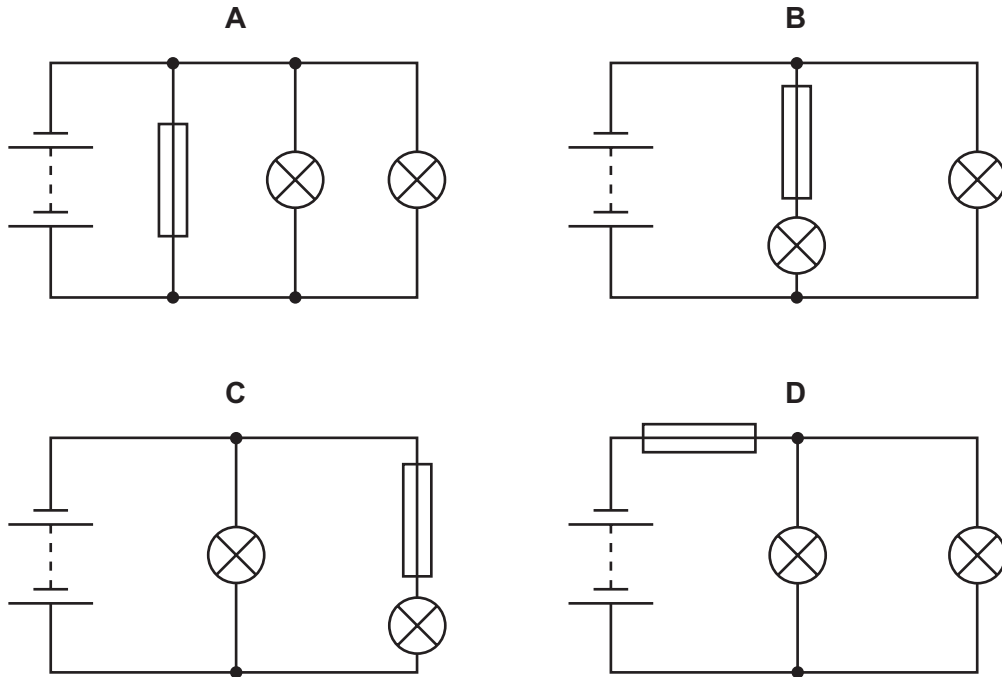

35 A transformer has 200 turns on its primary coil and is connected to a 240 V a.c. supply.

The output voltage of the transformer is 60 V a.c..

How many turns are on the secondary coil of the transformer?

A 20

B 50

C 72

D 800

- 36 A conducting wire is placed between the poles of a magnet. When an electric current in the wire is in the direction shown, then the force on the wire acts out of the page.

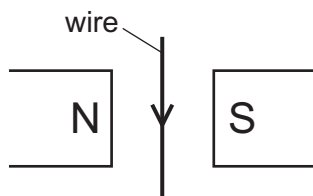

Three statements of different conditions and how the wire is affected are given.

- 1 The current is towards the top of the page and the direction of the magnetic field is unchanged then the force produced acts into the page.
- 2 The current is towards the bottom of the page and the magnetic field is reversed then the force produced acts into the page.
- 3 The current in the wire is alternating and the wire vibrates into and out of the page.

Which statements are correct?

- A** 1 and 2 only **B** 1 and 3 only **C** 2 and 3 only **D** 1, 2 and 3
- 37 A nuclide of the element iron has the symbol shown.



What does a neutral atom of this nuclide contain?

	protons	neutrons	electrons
A	26	30	26
B	26	56	30
C	30	26	56
D	56	26	30

- 38 What is the nucleon number of a nuclide?

- A** the number of neutrons in the nucleus
B the number of protons in the nucleus
C the number of protons minus the number of neutrons in the nucleus
D the number of protons plus the number of neutrons in the nucleus

- 39 A thin sheet of paper is placed between a radioactive source and a radiation detector. The count rate falls to a very low reading.

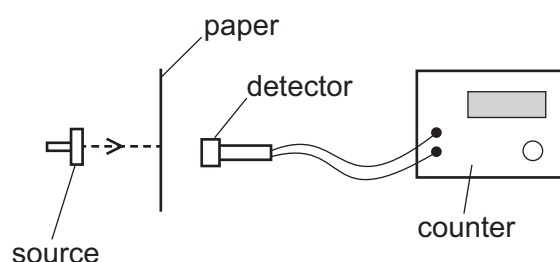

From this result, which type of radiation is the source emitting?

- A α -particles
 - B β -particles
 - C γ -rays
 - D X-rays
- 40 In 1986 the Chernobyl nuclear power station in Ukraine suffered a meltdown.

This caused background radiation in many countries, thousands of kilometres from Chernobyl, to increase.

What was transported in the atmosphere to these countries to cause this rise in background radiation?

- A α -particles
- B β -particles
- C γ -rays
- D radioactive isotopes

Permission to reproduce items where third-party owned material protected by copyright is included has been sought and cleared where possible. Every reasonable effort has been made by the publisher (UCLES) to trace copyright holders, but if any items requiring clearance have unwittingly been included, the publisher will be pleased to make amends at the earliest possible opportunity.

To avoid the issue of disclosure of answer-related information to candidates, all copyright acknowledgements are reproduced online in the Cambridge Assessment International Education Copyright Acknowledgements Booklet. This is produced for each series of examinations and is freely available to download at www.cambridgeinternational.org after the live examination series.

Cambridge Assessment International Education is part of the Cambridge Assessment Group. Cambridge Assessment is the brand name of the University of Cambridge Local Examinations Syndicate (UCLES), which itself is a department of the University of Cambridge.



Cambridge IGCSE™

PHYSICS

0625/11

Paper 1 Multiple Choice (Core)

May/June 2020

MARK SCHEME

Maximum Mark: 40

Published

Students did not sit exam papers in the June 2020 series due to the Covid-19 global pandemic.

This mark scheme is published to support teachers and students and should be read together with the question paper. It shows the requirements of the exam.

Mark schemes should usually be read together with the Principal Examiner Report for Teachers. However, because students did not sit exam papers, there is no Principal Examiner Report for Teachers for the June 2020 series.

Cambridge International will not enter into discussions about these mark schemes.

Cambridge International is publishing the mark schemes for the June 2020 series for most Cambridge IGCSE™ and Cambridge International A & AS Level components, and some Cambridge O Level components.

This document consists of **3** printed pages.

Question	Answer	Marks
1	B	1
2	C	1
3	A	1
4	D	1
5	D	1
6	B	1
7	A	1
8	B	1
9	C	1
10	B	1
11	C	1
12	A	1
13	D	1
14	B	1
15	A	1
16	B	1
17	A	1
18	A	1
19	C	1
20	C	1
21	B	1
22	C	1
23	A	1
24	C	1
25	A	1
26	B	1
27	D	1
28	C	1

Question	Answer	Marks
29	C	1
30	C	1
31	C	1
32	B	1
33	A	1
34	D	1
35	B	1
36	D	1
37	A	1
38	D	1
39	A	1
40	D	1



Cambridge IGCSE™

PHYSICS

0625/12

Paper 1 Multiple Choice (Core)

May/June 2020

45 minutes

You must answer on the multiple choice answer sheet.

You will need: Multiple choice answer sheet
Soft clean eraser
Soft pencil (type B or HB is recommended)

INSTRUCTIONS

- There are **forty** questions on this paper. Answer **all** questions.
- For each question there are four possible answers **A, B, C** and **D**. Choose the **one** you consider correct and record your choice in soft pencil on the multiple choice answer sheet.
- Follow the instructions on the multiple choice answer sheet.
- Write in soft pencil.
- Write your name, centre number and candidate number on the multiple choice answer sheet in the spaces provided unless this has been done for you.
- Do **not** use correction fluid.
- Do **not** write on any bar codes.
- You may use a calculator.
- Take the weight of 1.0 kg to be 10 N (acceleration of free fall = 10 m/s^2).

INFORMATION

- The total mark for this paper is 40.
- Each correct answer will score one mark. A mark will not be deducted for a wrong answer.
- Any rough working should be done on this question paper.

This document has **20** pages. Blank pages are indicated.



- 1 Five athletes P, Q, R, S and T compete in a race. The table shows the finishing times for the athletes.

athlete	P	Q	R	S	T
finishing time / s	22.50	24.40	25.20	26.50	23.20

Which statement is correct?

- A** Athlete P won the race and was 0.70 s ahead of the athlete in second place.
B Athlete P won the race and was 1.90 s ahead of the athlete in second place.
C Athlete S won the race and was 1.30 s ahead of the athlete in second place.
D Athlete S won the race and was 2.10 s ahead of the athlete in second place.
- 2 The graph shows how the speed of an object varies with time.

At which labelled time is the acceleration greatest?

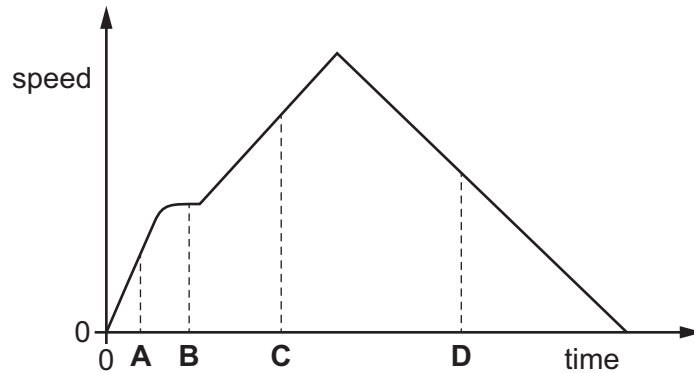

- 3 Which statement about acceleration is correct?
- A** It is related to the changing speed of an object.
B It is the distance an object travels in one second.
C It is the force acting on an object divided by the distance it travels in one second.
D It is the force acting on an object when it is near to the Earth.

- 4 Two metal blocks P and Q have identical dimensions. They hang on identical spring balances.

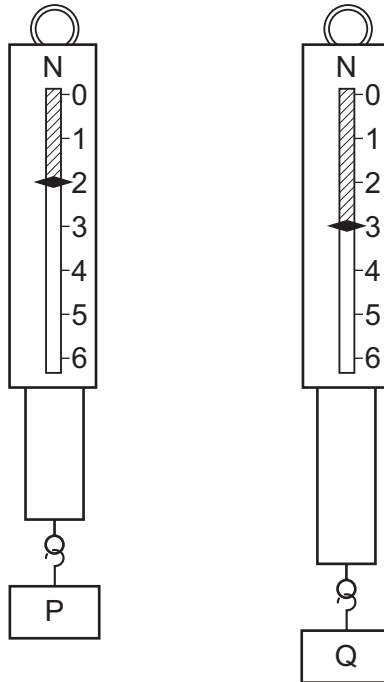

Which statement about P and Q is correct?

- A They have different volumes and different weights.
 - B They have different volumes and equal weights.
 - C They have equal volumes and equal weights.
 - D They have equal volumes and different weights.
- 5 A space probe is taken from the Earth to Mars.

The force of gravity on the surface of Mars is less than the force of gravity on the surface of the Earth.

How do the weight and the mass of a space probe on the surface of Mars compare to their values when the probe is on the surface of the Earth?

	weight on Mars	mass on Mars
A	decreased	decreased
B	decreased	unchanged
C	unchanged	decreased
D	unchanged	unchanged

- 6 Water has a density of 1000 kg/m^3 .

A rectangular swimming pool has an average depth of 1.6 m.

The length of the pool is 25 m.

The width of the pool is 10 m.

What is the mass of the water in the swimming pool?

- A** 2.5 kg **B** 400 kg **C** 400 000 kg **D** 800 000 kg

- 7 The diagram shows an extension–load graph for a spring.

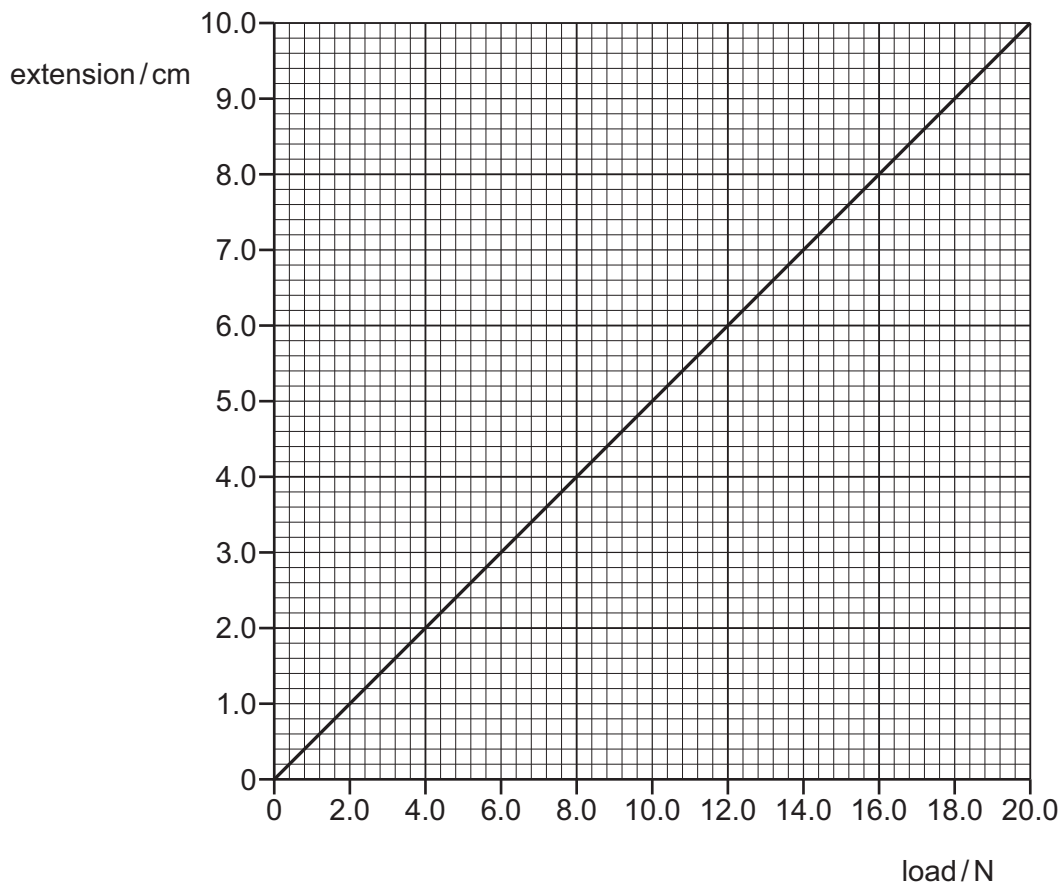

An empty can of weight 3.0 N is suspended from the spring.

Liquid is poured into the can until the extension is 8.0 cm.

What is the weight of the liquid?

- A** 4.0 N **B** 10.0 N **C** 13.0 N **D** 16.0 N

- 8 What is meant by the moment of a force on an object?
- A the magnitude of the force on the object
 - B the direction of the force on the object
 - C the time for which the force acts on the object
 - D the turning effect of the force on the object
- 9 Which energy resource is **not** renewable?
- A geothermal
 - B nuclear fission
 - C solar
 - D wind
- 10 Two motors X and Y lift loads of the same weight through the same vertical distance.
Motor X is more efficient than motor Y.
Which statement about the motors is correct?
- A The useful energy output of motor X is larger than that of motor Y.
 - B The useful energy output of motor X is smaller than that of motor Y.
 - C The energy input of motor X is larger than that of motor Y.
 - D The energy input of motor X is smaller than that of motor Y.

11 A man can either take an escalator or a lift to travel up between two floors in a hotel.

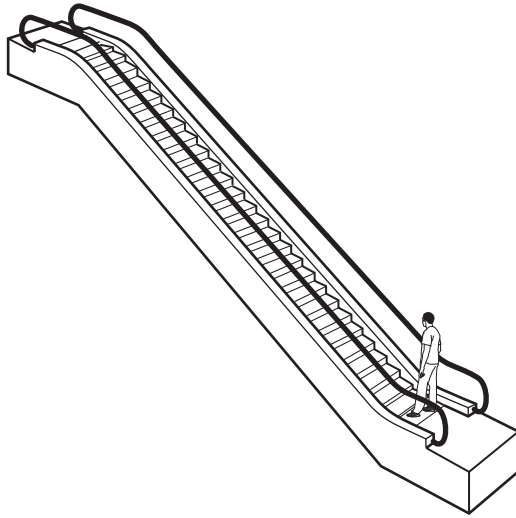

escalator

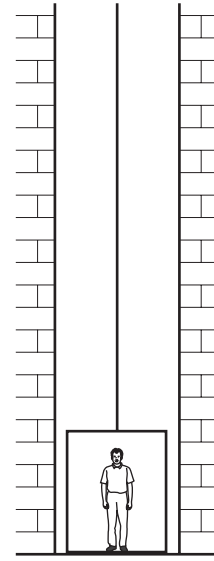

lift

The escalator takes 20 seconds to carry the man between the two floors. The useful work done against gravity is W . The useful power developed is P .

The lift takes 30 seconds to carry the same man between the same two floors.

How much useful work against gravity is done by the lift, and how much useful power is developed by the lift?

	useful work done against gravity by lift	useful power developed by lift
A	more than W	less than P
B	more than W	P
C	W	less than P
D	W	P

12 The diagram shows a solid block resting on a bench. The dimensions of the block are shown.

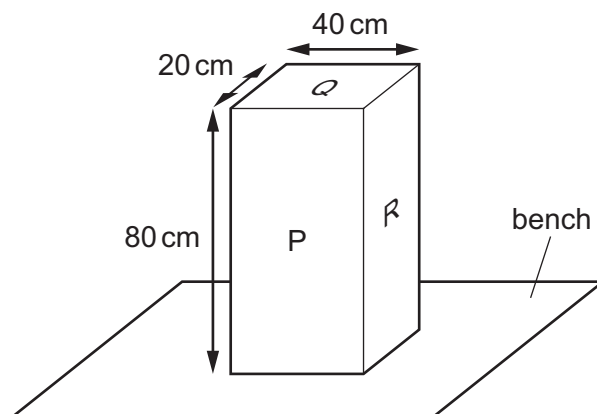

On which labelled surface should the block rest to produce the smallest pressure on the bench?

- A P
- B Q
- C R
- D P, Q and R produce the same pressure

13 A beaker contains a liquid.

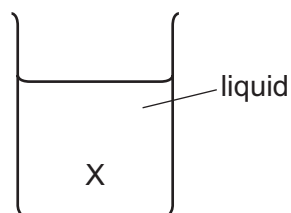

On what does the liquid pressure at position X depend?

- A both the density of the liquid and the depth of X below the surface
- B both the surface area of the liquid and the depth of X below the surface
- C both the surface area of the liquid and the volume of the liquid
- D the depth of X below the surface only

14 Evaporation occurs from the surface of a pool of water.

Which statement describes this change of state?

- A Electrons move from the liquid and become a gas.
- B Molecules that move from the liquid have the same energy as those that stay in the liquid.
- C The more energetic molecules escape the liquid.
- D The more energetic molecules remain in the liquid.

- 15 A gas, in a sealed container, is compressed slowly so that its temperature does not change.

What happens to the molecules of the gas as a result of this compression?

- A The average speed of the molecules increases.
- B The average force in a collision between a molecule and the container increases.
- C There are more frequent collisions between molecules and the container.
- D The volume of each molecule decreases.

- 16 The diagram shows a liquid-in-glass thermometer.



What is the temperature difference between the two fixed points on the Celsius scale?

- A 10°C
 - B 100°C
 - C 110°C
 - D 120°C
- 17 A metal block is left overnight in a cool, shady room. In the morning, the metal block is moved into warm surroundings.

Which statement about the metal block is correct in the morning?

- A The internal energy of the metal block increases.
- B The temperature of the metal block decreases.
- C Convection transfers energy throughout the metal block.
- D The metal contracts slightly.

- 18 The diagrams show four blocks of steel. The blocks are all drawn to the same scale.

The same quantity of thermal energy is given to each block.

Which block shows the greatest rise in temperature?

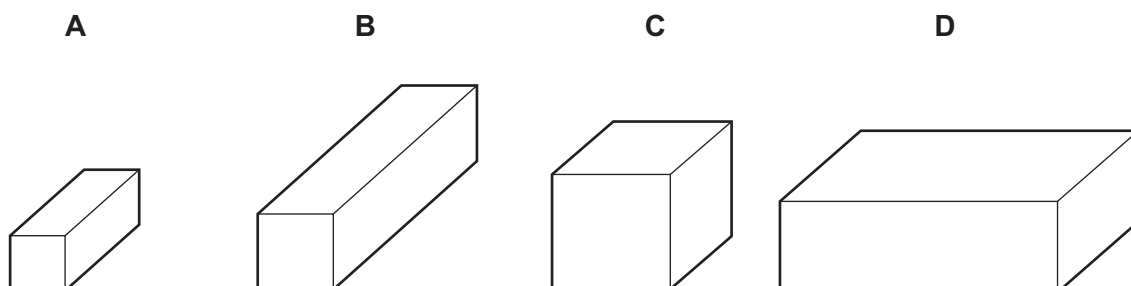

- 19 A room is heated by a radiator. The diagrams X and Y show two possible circulations of hot air, which heat the room.

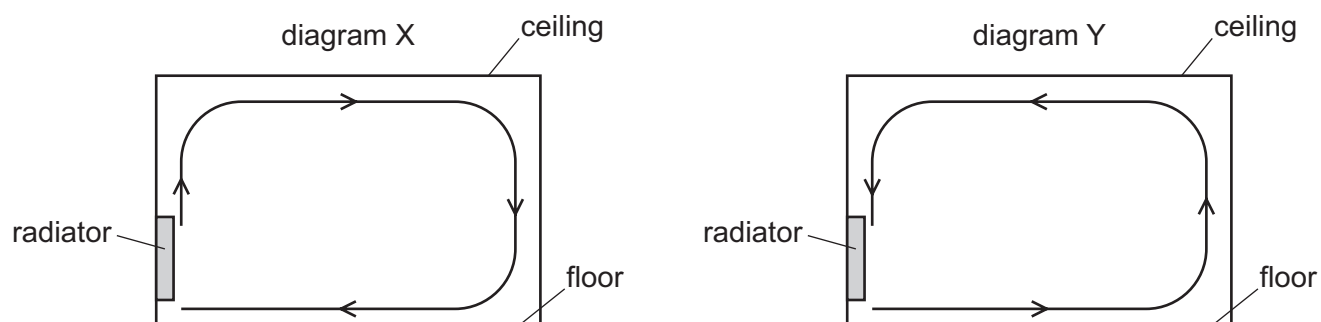

Which diagram and reason explain the heating of the room by convection?

	diagram	reason
A	X	air density decreases when air is heated
B	X	air density increases when air is heated
C	Y	air density decreases when air is heated
D	Y	air density increases when air is heated

- 20 Two similar liquid-in-glass thermometers P and Q are placed in direct sunlight.

The bulb of thermometer P is painted white. The bulb of thermometer Q is painted black.

How and why would the thermometer readings differ?

- A** P would read higher than Q because black is a good absorber of radiation.
- B** P would read higher than Q because black is a poor absorber of radiation.
- C** P would read lower than Q because black is a good absorber of radiation.
- D** P would read lower than Q because black is a poor absorber of radiation.

21 The diagram shows a wave.

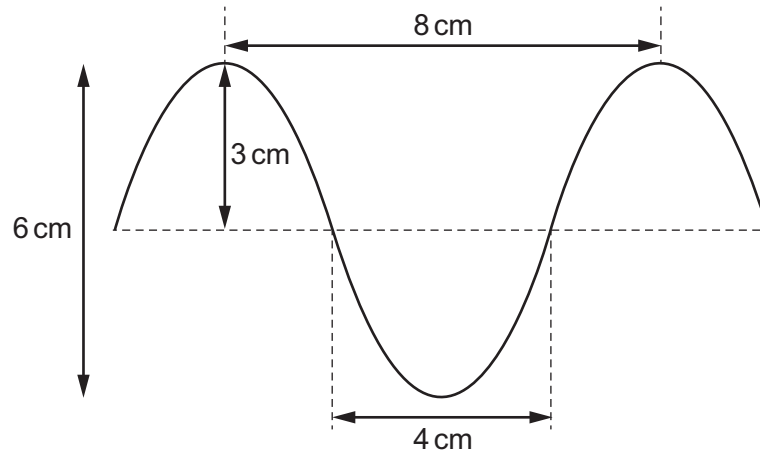

What are the amplitude and the wavelength of this wave?

	amplitude / cm	wavelength / cm
A	3	4
B	3	8
C	6	4
D	6	8

22 Waves travel more quickly on the surface of water when the water is deep.

A stone is dropped at point X into a pool of varying depth. The diagram shows the first three wavefronts on the surface of the pool.

The region between X and which labelled point is likely to be the deepest?

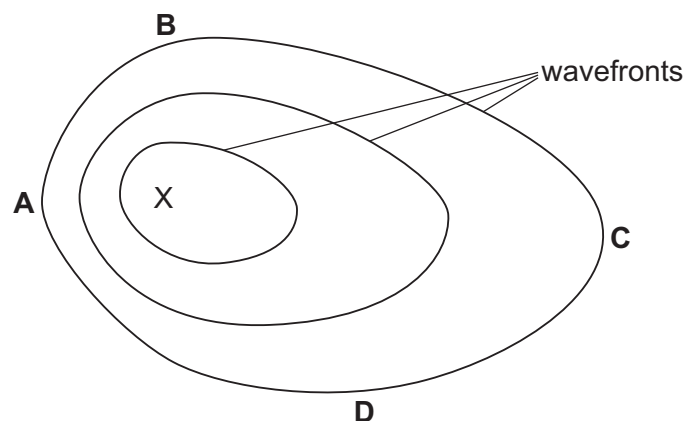

23 The diagram shows a ray of light incident on the surface of a glass block.

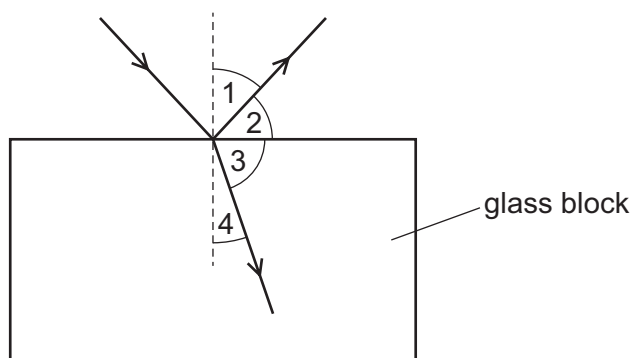

The ray of light is partially reflected back into the air and partially refracted into the glass block.

Which row correctly identifies the angle of reflection and the angle of refraction?

	angle of reflection	angle of refraction
A	1	3
B	1	4
C	2	3
D	2	4

24 A beam of light consists of yellow and blue light.

The beam of light is incident on a glass prism.

Which diagram is correct?

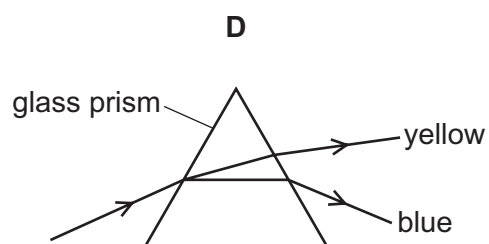
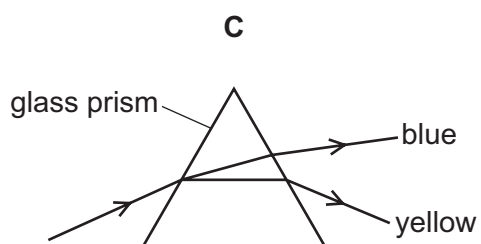
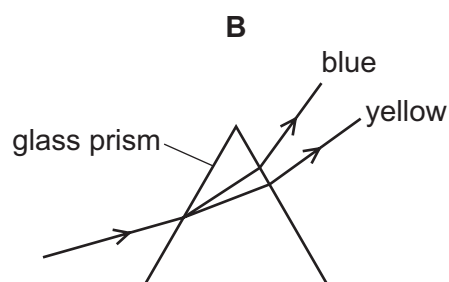
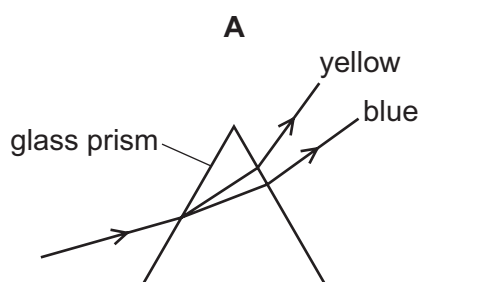

25 An intruder alarm sensor detects that a person is warmer than his surroundings.

Which type of electromagnetic wave does the sensor detect?

- A infrared
- B radio
- C ultraviolet
- D visible light

26 A dolphin sends out a sound wave. An echo returns 0.010 s later from a fish which is 7.5 m from the dolphin.

What is the speed of the sound wave in water?

- A 0.075 m/s
- B 0.15 m/s
- C 750 m/s
- D 1500 m/s

27 The diagrams show two bar magnets which are attracting each other.

Which diagram shows the magnetic field pattern between the poles?

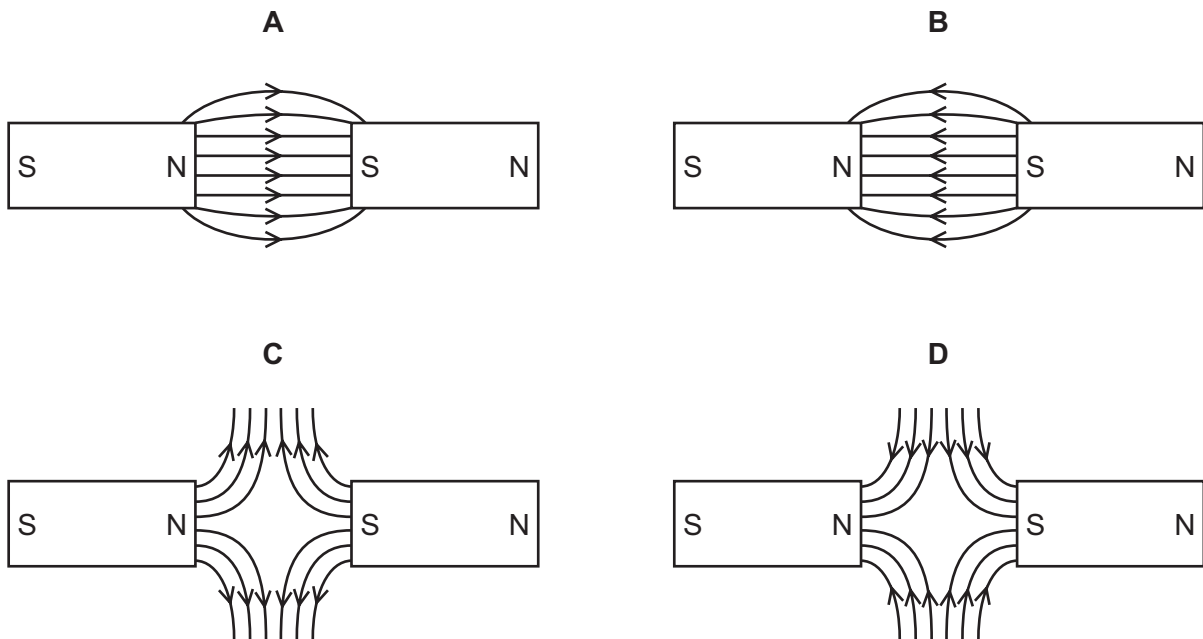

28 Four nails **A**, **B**, **C** and **D** are tested to find which makes the strongest permanent magnet.

One of the nails is placed against a bar magnet and the number of paper clips which the nail can support is recorded.

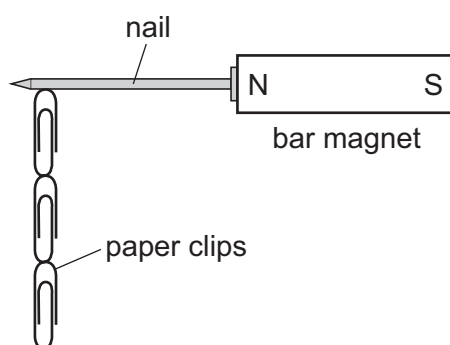

The bar magnet is then removed and the number of paper clips remaining attached to the nail is recorded. Each nail is tested individually.

Which nail becomes the strongest permanent magnet?

	number of paper clips attached to the nail	
	bar magnet present	bar magnet removed
A	2	0
B	2	1
C	4	3
D	5	2

29 A cloth is used to rub an uncharged plastic rod.

Both the rod and the cloth become charged.

Why does the plastic rod become negatively charged and the cloth become positively charged?

- A** The rod gains electrons and the cloth gains positive charges.
- B** The rod gains electrons and the cloth loses electrons.
- C** The rod loses electrons and the cloth gains electrons.
- D** The rod loses electrons and the cloth loses positive charges.

- 30 The diagram shows a circuit. The wire between P and Q can be removed and replaced by a circuit component.

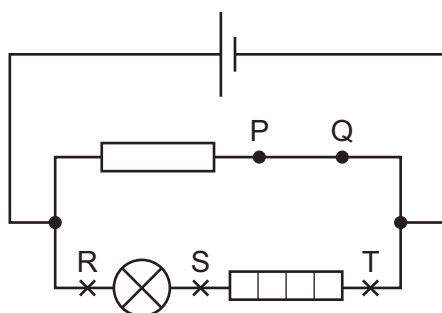

Where should a voltmeter be connected to measure the potential difference (p.d.) across the lamp?

- A between P and Q in place of the wire
 - B in parallel with R and S
 - C in parallel with R and T
 - D in parallel with S and T
- 31 A student uses the circuit shown to determine the resistance of two identical resistors.

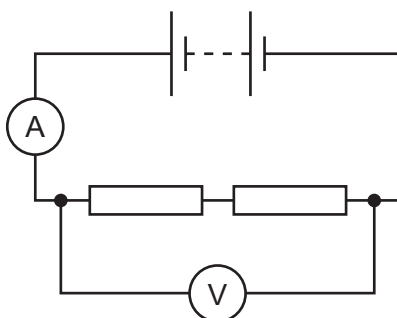

The voltmeter reading is 2.2 V and the ammeter reading is 0.25 A.

What is the resistance of each resistor?

- A 0.275Ω
- B 0.55Ω
- C 4.4Ω
- D 8.8Ω

32 The circuit shown contains five lamps J, K, L, M and N. All the lamps are glowing.

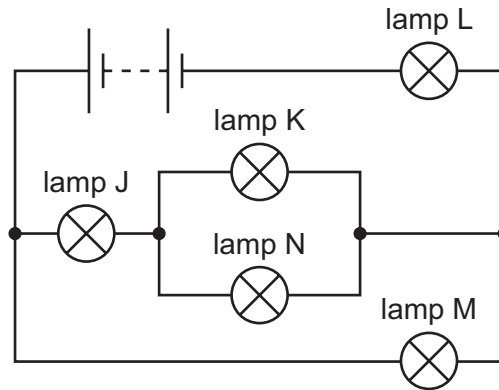

One lamp is removed and two other lamps go out.

Which lamp is removed?

- A lamp J
- B lamp K
- C lamp L
- D lamp M

33 The diagram shows a control circuit. The lamp is lit.

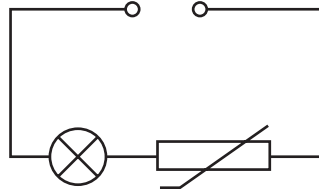

The temperature of the surroundings increases.

What will happen to the brightness of the lamp?

- A It will be brighter.
- B It will be less bright.
- C It will not change.
- D It will become brighter and then less bright.

34 A student constructs four circuits, each containing a fuse.

The fuse blows in one circuit and both lamps in the circuit go out.

In which circuit does the fuse blow and both lamps go out?

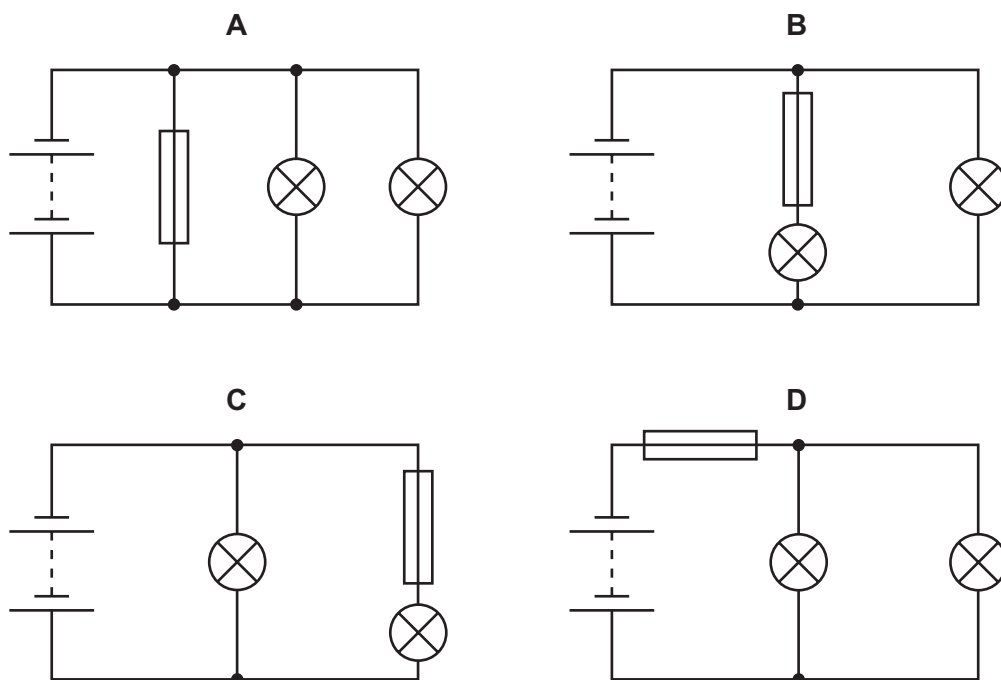

35 The diagrams P, Q and R show three voltage–time graphs.

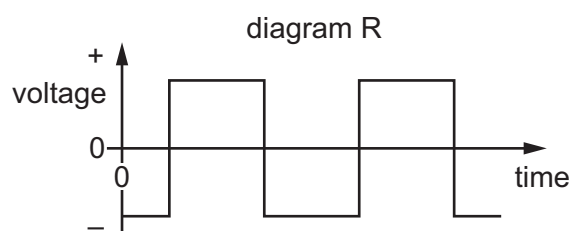
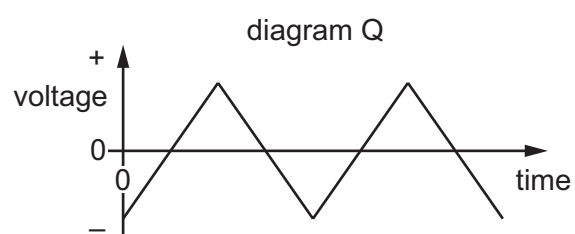
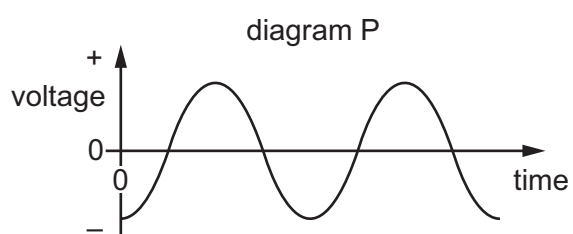

Which graphs show an alternating voltage?

A P and Q only **B** P and R only **C** Q and R only **D** P, Q and R

36 The diagram shows a transformer.

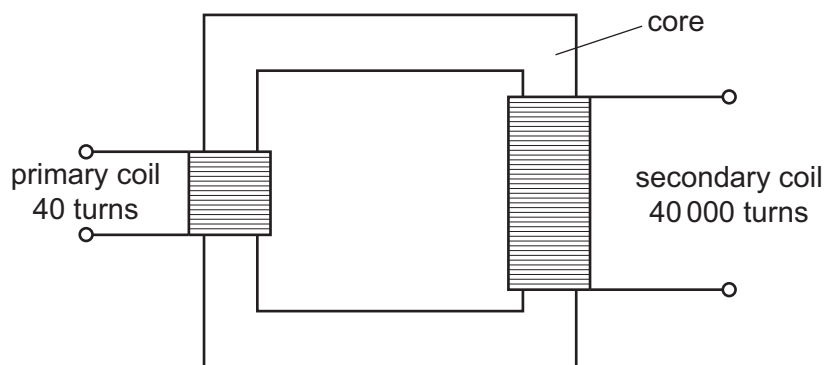

Which statement about this transformer is correct?

- A It can operate from a 12 V battery.
- B It has a core which is made of steel.
- C It steps the input voltage up by a factor of 1000.
- D It steps the input voltage down by a factor of 1000.

37 A nuclide of the element iron has the symbol shown.

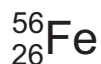

What does a neutral atom of this nuclide contain?

	protons	neutrons	electrons
A	26	30	26
B	26	56	30
C	30	26	56
D	56	26	30

38 Which statement about the nuclei of all atoms is correct?

- A They all contain electrons.
- B They are all always stable.
- C They all contain protons and electrons.
- D They all have a positive charge.

- 39 A thin sheet of paper is placed between a radioactive source and a radiation detector. The count rate falls to a very low reading.

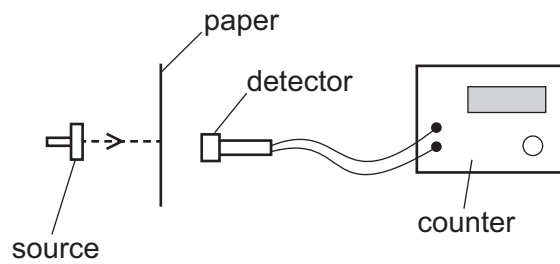

From this result, which type of radiation is the source emitting?

- A α -particles
 - B β -particles
 - C γ -rays
 - D X-rays
- 40 A radioactive isotope has a half-life of 120 minutes.
It emits radiation at a rate of 100 particles per second.
How long does it take for the rate of emission to fall to 25 particles per second?
- A 30 minutes
 - B 45 minutes
 - C 90 minutes
 - D 240 minutes

BLANK PAGE

Permission to reproduce items where third-party owned material protected by copyright is included has been sought and cleared where possible. Every reasonable effort has been made by the publisher (UCLES) to trace copyright holders, but if any items requiring clearance have unwittingly been included, the publisher will be pleased to make amends at the earliest possible opportunity.

To avoid the issue of disclosure of answer-related information to candidates, all copyright acknowledgements are reproduced online in the Cambridge Assessment International Education Copyright Acknowledgements Booklet. This is produced for each series of examinations and is freely available to download at www.cambridgeinternational.org after the live examination series.

Cambridge Assessment International Education is part of the Cambridge Assessment Group. Cambridge Assessment is the brand name of the University of Cambridge Local Examinations Syndicate (UCLES), which itself is a department of the University of Cambridge.



Cambridge IGCSE™

PHYSICS

0625/12

Paper 1 Multiple Choice (Core)

May/June 2020

MARK SCHEME

Maximum Mark: 40

Published

Students did not sit exam papers in the June 2020 series due to the Covid-19 global pandemic.

This mark scheme is published to support teachers and students and should be read together with the question paper. It shows the requirements of the exam.

Mark schemes should usually be read together with the Principal Examiner Report for Teachers. However, because students did not sit exam papers, there is no Principal Examiner Report for Teachers for the June 2020 series.

Cambridge International will not enter into discussions about these mark schemes.

Cambridge International is publishing the mark schemes for the June 2020 series for most Cambridge IGCSE™ and Cambridge International A & AS Level components, and some Cambridge O Level components.

This document consists of **3** printed pages.

Question	Answer	Marks
1	A	1
2	A	1
3	A	1
4	D	1
5	B	1
6	C	1
7	C	1
8	D	1
9	B	1
10	D	1
11	C	1
12	A	1
13	A	1
14	C	1
15	C	1
16	B	1
17	A	1
18	A	1
19	A	1
20	C	1
21	B	1
22	C	1
23	B	1
24	D	1
25	A	1
26	D	1
27	A	1
28	C	1

Question	Answer	Marks
29	B	1
30	B	1
31	C	1
32	A	1
33	A	1
34	D	1
35	D	1
36	C	1
37	A	1
38	D	1
39	A	1
40	D	1



Cambridge IGCSE™

PHYSICS

Paper 1 Multiple Choice (Core)

0625/13

May/June 2020

45 minutes

You must answer on the multiple choice answer sheet.

You will need: Multiple choice answer sheet
Soft clean eraser
Soft pencil (type B or HB is recommended)

INSTRUCTIONS

- There are **forty** questions on this paper. Answer **all** questions.
- For each question there are four possible answers **A**, **B**, **C** and **D**. Choose the **one** you consider correct and record your choice in soft pencil on the multiple choice answer sheet.
- Follow the instructions on the multiple choice answer sheet.
- Write in soft pencil.
- Write your name, centre number and candidate number on the multiple choice answer sheet in the spaces provided unless this has been done for you.
- Do **not** use correction fluid.
- Do **not** write on any bar codes.
- You may use a calculator.
- Take the weight of 1.0 kg to be 10 N (acceleration of free fall = 10 m/s^2).

INFORMATION

- The total mark for this paper is 40.
- Each correct answer will score one mark. A mark will not be deducted for a wrong answer.
- Any rough working should be done on this question paper.

This document has **20** pages. Blank pages are indicated.



- 1 Diagram 1 shows a solid, rectangular-sided block.

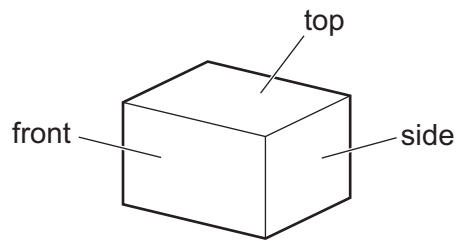

diagram 1

Diagram 2 shows the same block from the front and from the side.

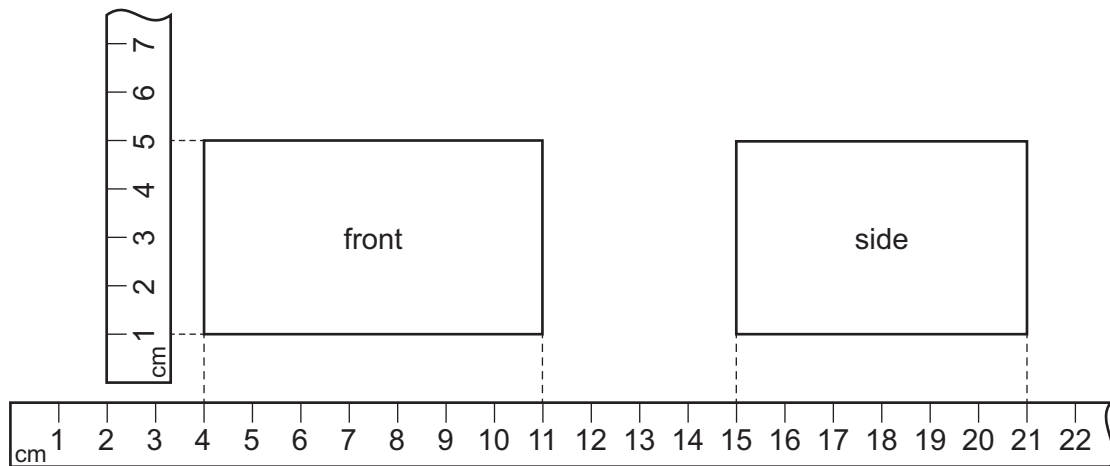
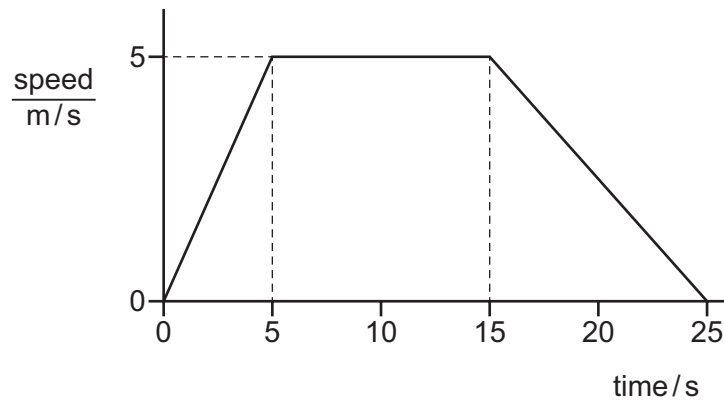

diagram 2

Metre rules have been shown close to the edges of the block.

What is the volume of the block?

- A** 120 cm^3 **B** 168 cm^3 **C** 264 cm^3 **D** 1155 cm^3
- 2 The speed–time graph shows the motion of an object.



How far does the object travel at constant speed?

- A** 25 m **B** 50 m **C** 75 m **D** 125 m

- 3 Which statement about acceleration is correct?
- A** It is related to the changing speed of an object.
- B** It is the distance an object travels in one second.
- C** It is the force acting on an object divided by the distance it travels in one second.
- D** It is the force acting on an object when it is near to the Earth.
- 4 Two metal blocks P and Q have identical dimensions. They hang on identical spring balances.

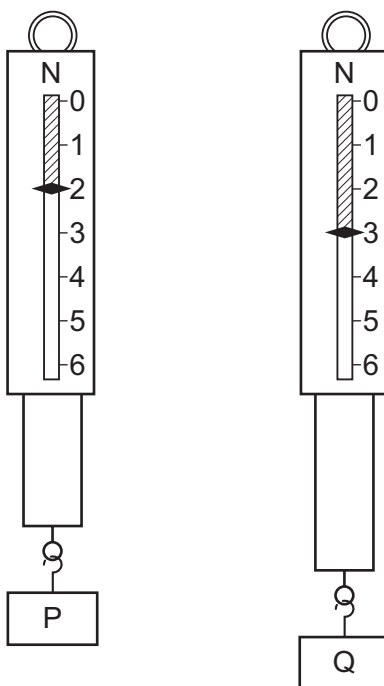

Which statement about P and Q is correct?

- A** They have different volumes and different weights.
- B** They have different volumes and equal weights.
- C** They have equal volumes and equal weights.
- D** They have equal volumes and different weights.
- 5 Which row gives the correct weight for the mass shown?

The value of g is 10 N/kg .

	mass/kg	weight/N
A	2	20
B	10	1
C	10	10
D	20	2

- 6 A rectangular gymnasium is 50 m long, 25 m wide and 8.0 m high.

The density of air is 1.2 kg/m^3 .

What is the best estimate of the mass of air in the gymnasium?

- A 0.00012 kg B 100 kg C 8300 kg D 12 000 kg
- 7 The diagram shows two of the three vertical forces acting on a hot-air balloon. The hot-air balloon is moving upwards at constant speed.

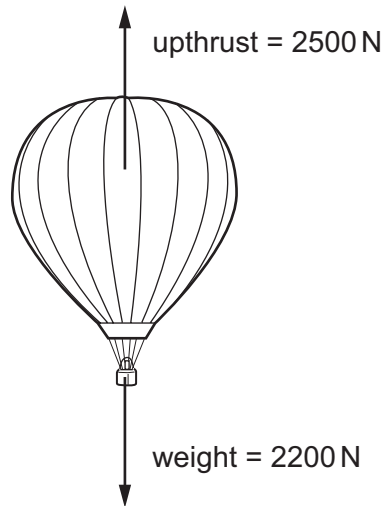

What is the air resistance acting on the hot-air balloon?

- A 300 N downwards
B 300 N upwards
C 4700 N downwards
D 4700 N upwards
- 8 Which statement about the moment of a force is **not** correct?
- A If an object is balanced about a pivot the resultant moment on the object must be zero.
B The moment of a force is a measure of its turning effect.
C The moment of a force about a point is equal to: force \times perpendicular distance from the point.
D The moment of a force about a point increases when the perpendicular distance of the force from the point decreases.

- 9 A mass bounces up and down on a steel spring. The diagram shows the mass and the spring at different points during the motion.

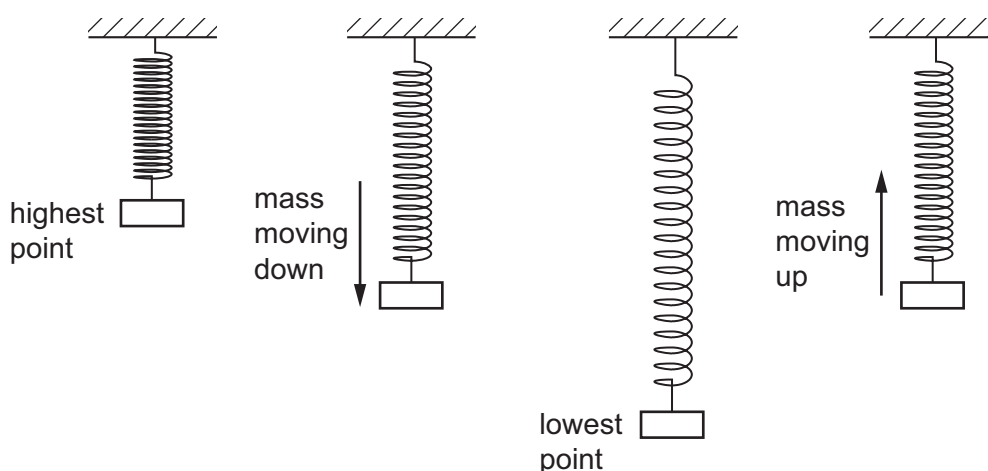

At which point does the mass have the least gravitational potential energy and at which point is the most elastic energy stored in the spring?

	least amount of gravitational potential energy	most elastic energy stored in spring
A	mass moving down	mass moving up
B	mass moving down	lowest point
C	lowest point	mass moving up
D	lowest point	lowest point

- 10 Which energy resource stores kinetic energy?

- A** coal
- B** nuclear fission
- C** solar
- D** wind

11 A man can either take an escalator or a lift to travel up between two floors in a hotel.

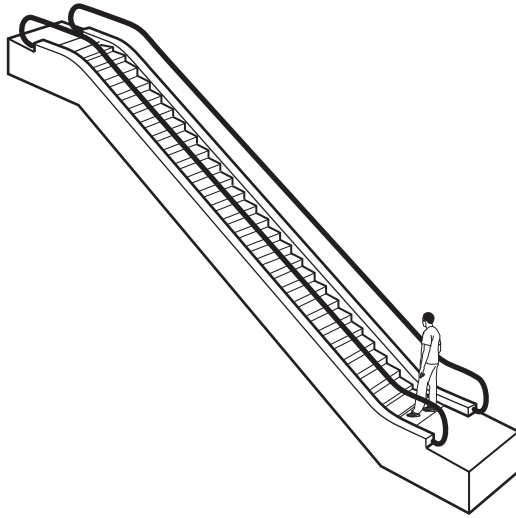

escalator

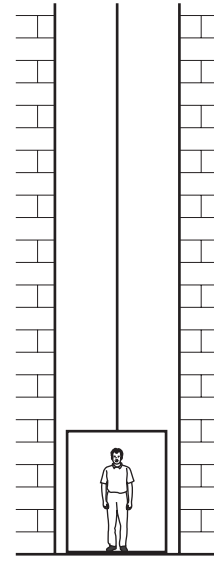

lift

The escalator takes 20 seconds to carry the man between the two floors. The useful work done against gravity is W . The useful power developed is P .

The lift takes 30 seconds to carry the same man between the same two floors.

How much useful work against gravity is done by the lift, and how much useful power is developed by the lift?

	useful work done against gravity by lift	useful power developed by lift
A	more than W	less than P
B	more than W	P
C	W	less than P
D	W	P

- 12 The diagram shows a solid block resting on a bench. The dimensions of the block are shown.

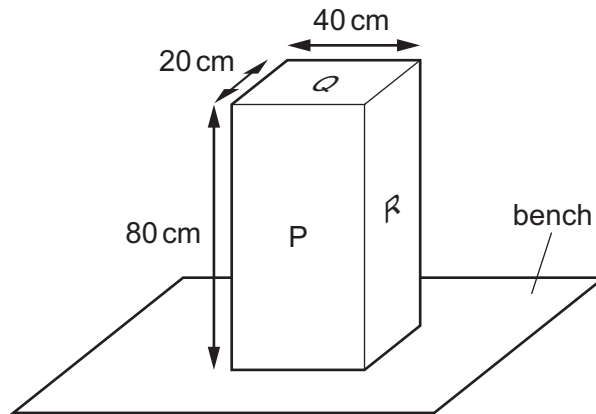

On which labelled surface should the block rest to produce the smallest pressure on the bench?

- A** P
B Q
C R
D P, Q and R produce the same pressure
- 13 The diagram shows a U-shaped glass tube, closed at one end by a tap. The glass tube contains a liquid as shown.

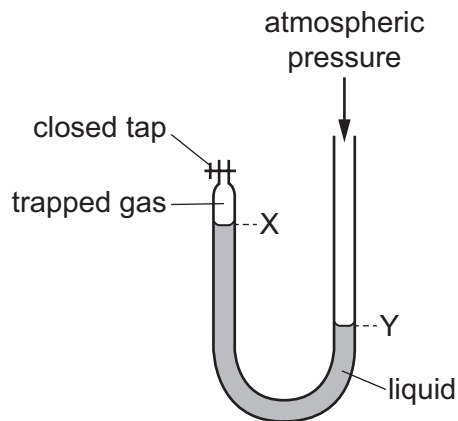

Some of the trapped gas is removed.

What will happen to the levels X and Y?

	level X	level Y
A	higher	lower
B	higher	higher
C	lower	higher
D	lower	lower

14 What is the correct particle diagram for a solid?

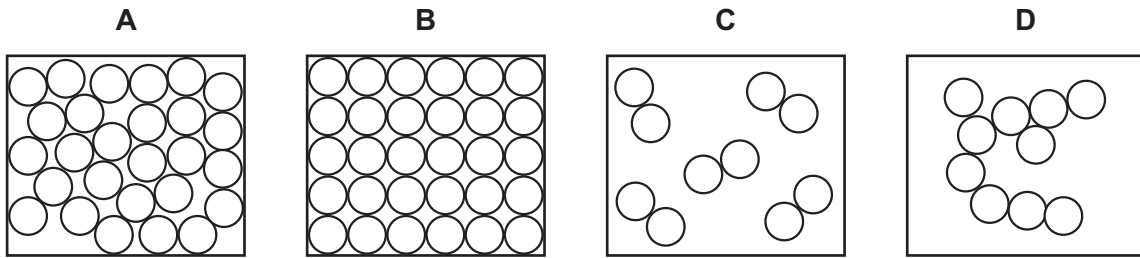

15 A sealed box contains a fixed mass of gas.

Which action results in each molecule of the gas colliding with the walls of the container less frequently and with a smaller force?

- A Decrease the temperature of the gas.
- B Decrease the volume of the container.
- C Increase the temperature of the gas.
- D Increase the volume of the container.

16 The diagram shows a liquid-in-glass thermometer.



Which row gives the correct labels for the thermometer?

	X	Y
A	water	narrow tube of uniform diameter
B	alcohol	narrow tube of uniform diameter
C	water	this end immersed in substance to be measured
D	alcohol	this end immersed in substance to be measured

17 The diagrams show four blocks of steel. The blocks are all drawn to the same scale.

The same quantity of thermal energy is given to each block.

Which block shows the greatest rise in temperature?

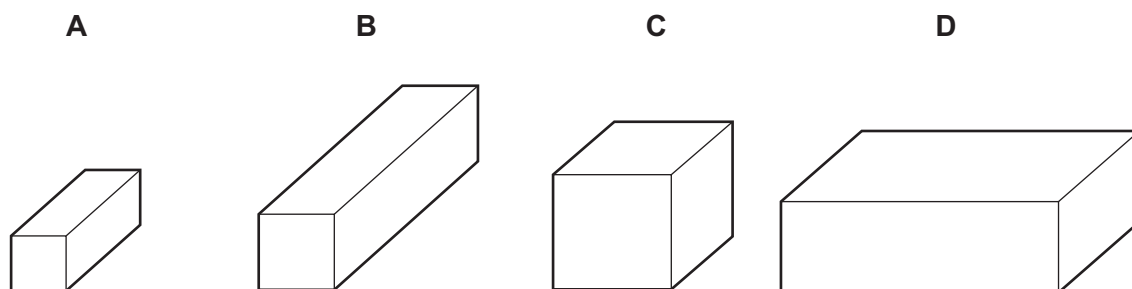

18 A gas is cooled so that its molecules move more slowly, come closer together and do not move freely.

Which process is being described?

- A boiling
- B condensing
- C freezing
- D melting

19 The diagram shows a vacuum flask used to keep a liquid warm.

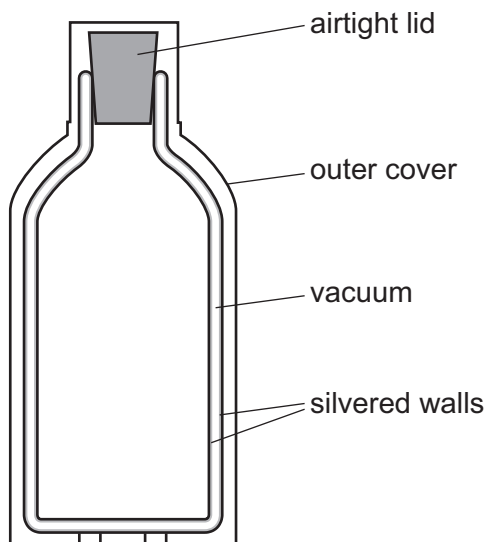

Which methods of heat loss are reduced by the **vacuum** between the silvered walls?

- A conduction only
- B conduction and convection only
- C convection and radiation only
- D conduction, convection and radiation

- 20 Equal volumes of water at 100°C are put in four containers. Two containers have matt black sides and two containers have shiny white sides. One of each type of container has a lid.

The containers are left for two minutes.

Which container has the highest temperature?

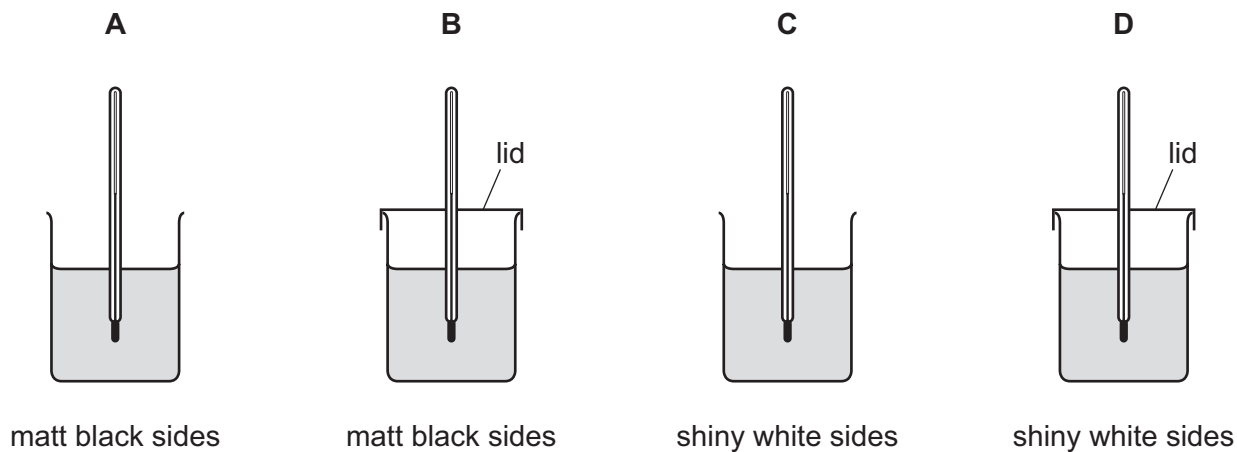

- 21 The diagram shows a wave.

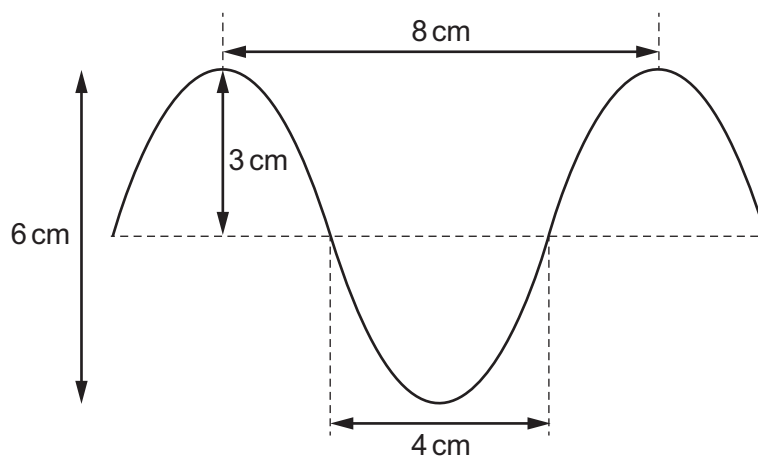

What are the amplitude and the wavelength of this wave?

	amplitude / cm	wavelength / cm
A	3	4
B	3	8
C	6	4
D	6	8

- 22 Waves travel more quickly on the surface of water when the water is deep.

A stone is dropped at point X into a pool of varying depth. The diagram shows the first three wavefronts on the surface of the pool.

The region between X and which labelled point is likely to be the deepest?

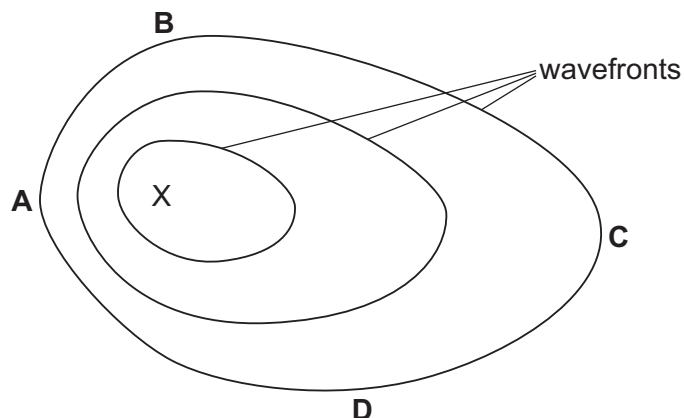

- 23 The diagram shows a ray of light incident on a plane mirror.

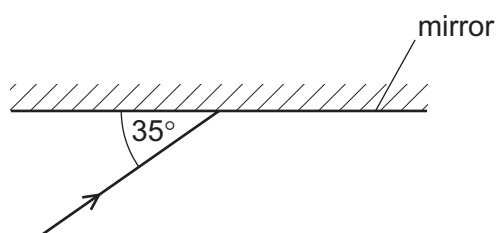

The angle between the ray and the mirror is 35° .

The ray is reflected by the mirror.

What is the angle of reflection?

- A 35° B 55° C 70° D 110°
- 24 A beam of white light is split into a spectrum of seven colours.

Which name is given to this process?

- A diffraction
 B dispersion
 C reflection
 D refraction

25 An intruder alarm sensor detects that a person is warmer than his surroundings.

Which type of electromagnetic wave does the sensor detect?

- A infrared
- B radio
- C ultraviolet
- D visible light

26 A tuning fork produces a sound when it vibrates.

What is the effect on the sound produced when the tuning fork vibrates more times every second and with a larger amplitude?

- A higher pitch and less loud
- B higher pitch and louder
- C lower pitch and less loud
- D lower pitch and louder

27 The diagram shows a magnet with some plotting compasses. The compasses show the direction of the magnetic field of the magnet.

Which plotting compass has the needle pointing in the wrong direction?

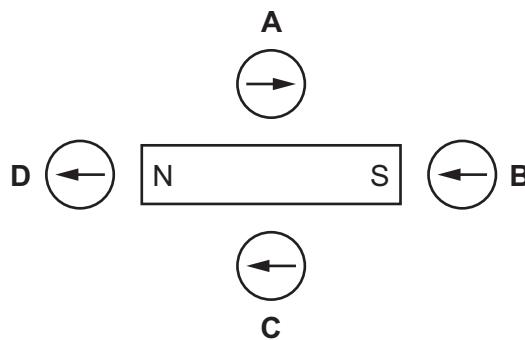

28 Four nails **A**, **B**, **C** and **D** are tested to find which makes the strongest permanent magnet.

One of the nails is placed against a bar magnet and the number of paper clips which the nail can support is recorded.

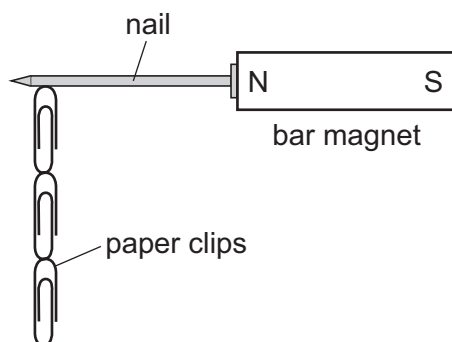

The bar magnet is then removed and the number of paper clips remaining attached to the nail is recorded. Each nail is tested individually.

Which nail becomes the strongest permanent magnet?

	number of paper clips attached to the nail	
	bar magnet present	bar magnet removed
A	2	0
B	2	1
C	4	3
D	5	2

29 The diagram shows a positively charged conducting sphere and a wire connected to earth.

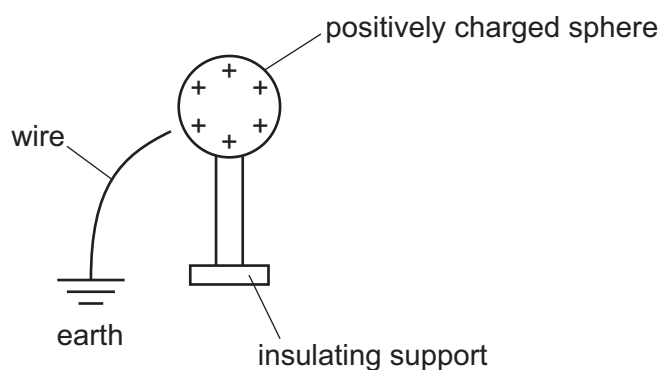

What happens when the wire is touched onto the sphere?

- A** Electrons flow from earth to the sphere.
- B** Electrons flow from the sphere to earth.
- C** Positive charges flow from earth to the sphere.
- D** Positive charges flow from the sphere to earth.

30 Three electrical quantities are listed.

- potential difference
- electromotive force
- current

Which quantities are measured in volts?

- A** potential difference only
B potential difference and current only
C potential difference and electromotive force only
D potential difference, electromotive force and current

31 A student uses the circuit shown to determine the resistance of two identical resistors.

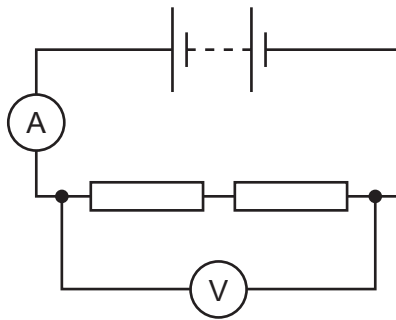

The voltmeter reading is 2.2 V and the ammeter reading is 0.25 A.

What is the resistance of each resistor?

- A** 0.275 Ω **B** 0.55 Ω **C** 4.4 Ω **D** 8.8 Ω

32 The diagram shows part of a circuit containing three identical lamps.

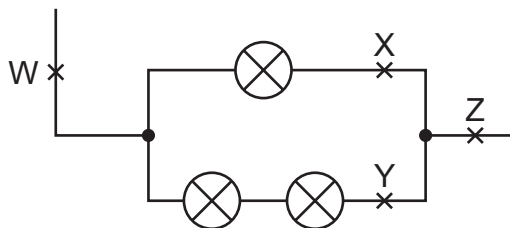

At which two points do the currents have the same value?

- A** W and X **B** W and Z **C** X and Y **D** Y and Z

33 Which circuit contains a thermistor and a heater?

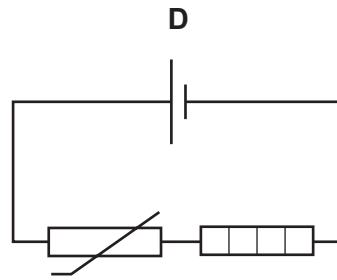
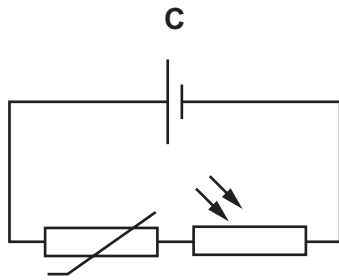
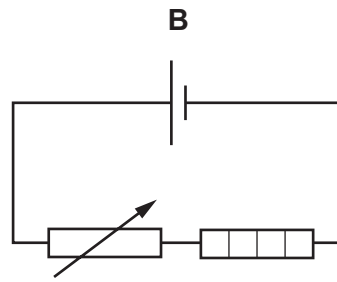
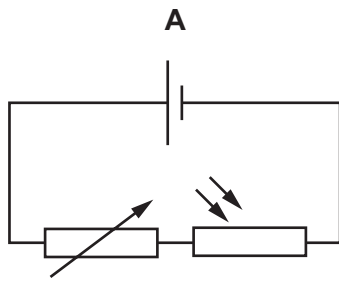

34 A student constructs four circuits, each containing a fuse.

The fuse blows in one circuit and both lamps in the circuit go out.

In which circuit does the fuse blow and both lamps go out?

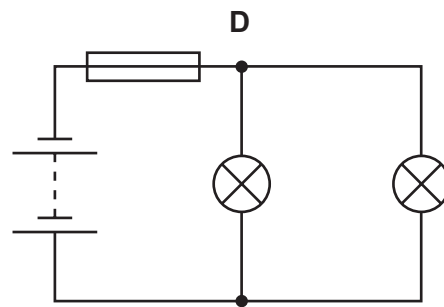
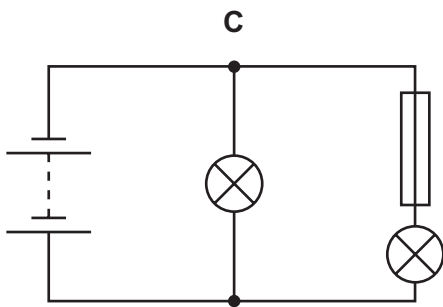
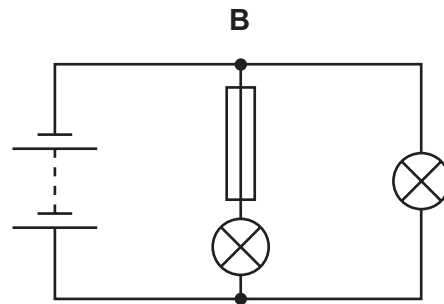
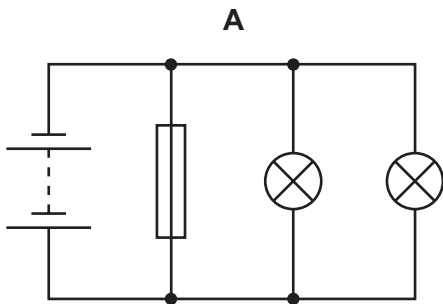

35 The graphs show how the currents in three circuits vary with time.

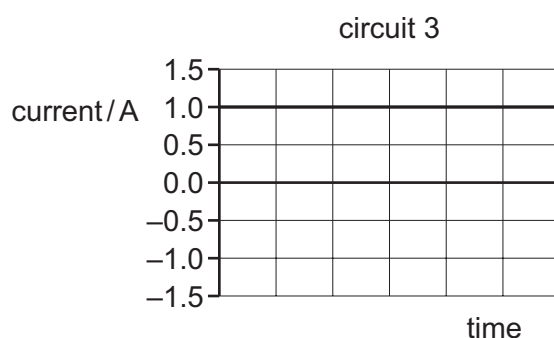
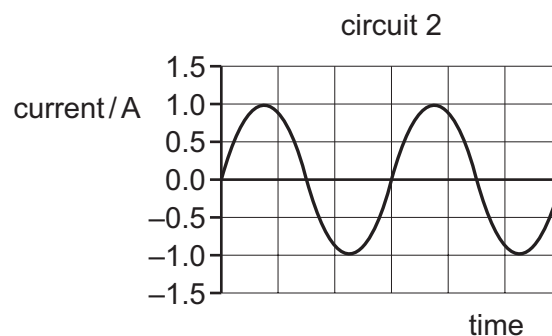
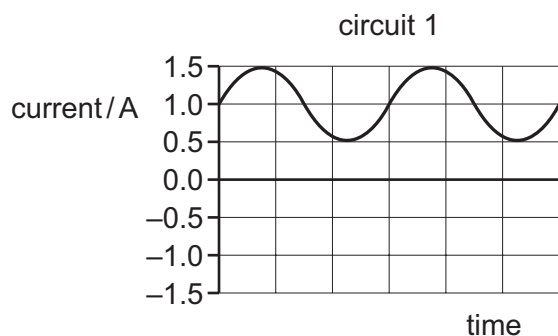

In which circuits is there a direct current?

- A** 1 and 2 **B** 1 and 3 **C** 2 only **D** 3 only

36 The diagram represents the transmission of electricity from a power station to homes that are many kilometres away. Two transformers are labelled X and Y.

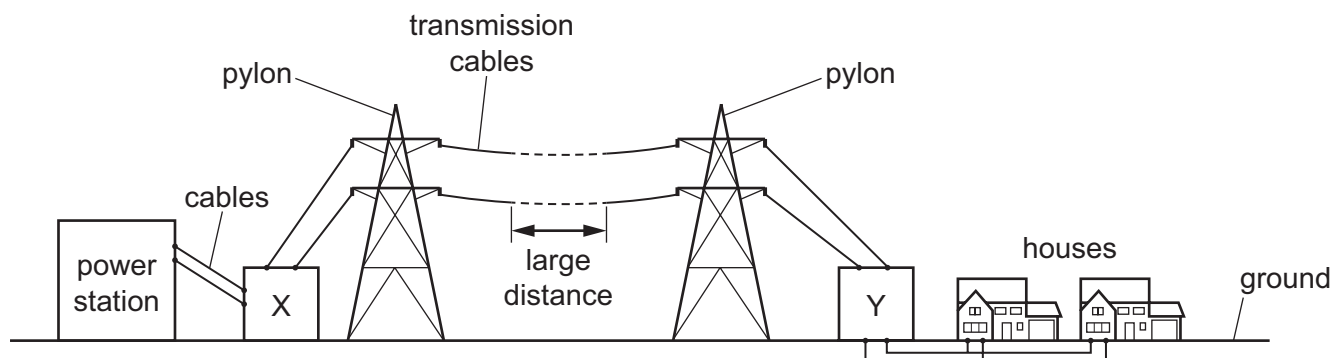

What type of transformers are X and Y?

	X	Y
A	step-down transformer	step-down transformer
B	step-down transformer	step-up transformer
C	step-up transformer	step-down transformer
D	step-up transformer	step-up transformer

37 A nuclide of the element iron has the symbol shown.

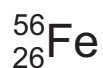

What does a neutral atom of this nuclide contain?

	protons	neutrons	electrons
A	26	30	26
B	26	56	30
C	30	26	56
D	56	26	30

38 The diagram shows an early model of the structure of an atom.

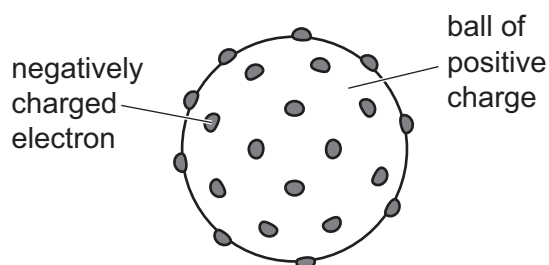

This early model is different from the atomic model accepted today.

Which statement about the early model is **not** included in the model accepted today?

- A** The atom is mainly filled with a ball of positive charge.
- B** The electrons are negatively charged.
- C** There are positive and negative charges.
- D** There are small particles called electrons.

- 39 A thin sheet of paper is placed between a radioactive source and a radiation detector. The count rate falls to a very low reading.

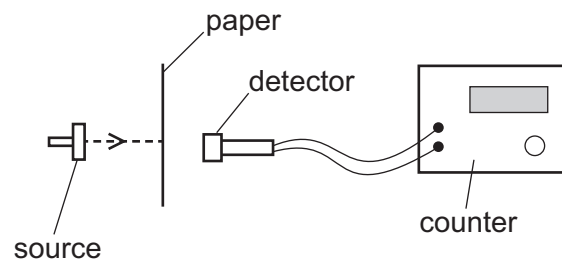

From this result, which type of radiation is the source emitting?

- A α -particles
 - B β -particles
 - C γ -rays
 - D X-rays
- 40 Why should all radioactive materials be handled carefully?
- A They all make anything they touch radioactive.
 - B They all catch fire very easily.
 - C They all emit ionising radiation.
 - D They all have long half-lives.

BLANK PAGE

Permission to reproduce items where third-party owned material protected by copyright is included has been sought and cleared where possible. Every reasonable effort has been made by the publisher (UCLES) to trace copyright holders, but if any items requiring clearance have unwittingly been included, the publisher will be pleased to make amends at the earliest possible opportunity.

To avoid the issue of disclosure of answer-related information to candidates, all copyright acknowledgements are reproduced online in the Cambridge Assessment International Education Copyright Acknowledgements Booklet. This is produced for each series of examinations and is freely available to download at www.cambridgeinternational.org after the live examination series.

Cambridge Assessment International Education is part of the Cambridge Assessment Group. Cambridge Assessment is the brand name of the University of Cambridge Local Examinations Syndicate (UCLES), which itself is a department of the University of Cambridge.



Cambridge IGCSE™

PHYSICS

0625/13

Paper 1 Multiple Choice (Core)

May/June 2020

MARK SCHEME

Maximum Mark: 40

Published

Students did not sit exam papers in the June 2020 series due to the Covid-19 global pandemic.

This mark scheme is published to support teachers and students and should be read together with the question paper. It shows the requirements of the exam.

Mark schemes should usually be read together with the Principal Examiner Report for Teachers. However, because students did not sit exam papers, there is no Principal Examiner Report for Teachers for the June 2020 series.

Cambridge International will not enter into discussions about these mark schemes.

Cambridge International is publishing the mark schemes for the June 2020 series for most Cambridge IGCSE™ and Cambridge International A & AS Level components, and some Cambridge O Level components.

This document consists of **3** printed pages.

Question	Answer	Marks
1	B	1
2	B	1
3	A	1
4	D	1
5	A	1
6	D	1
7	A	1
8	D	1
9	D	1
10	D	1
11	C	1
12	A	1
13	A	1
14	B	1
15	A	1
16	B	1
17	A	1
18	B	1
19	B	1
20	D	1
21	B	1
22	C	1
23	B	1
24	B	1
25	A	1
26	B	1
27	C	1
28	C	1

Question	Answer	Marks
29	A	1
30	C	1
31	C	1
32	B	1
33	D	1
34	D	1
35	B	1
36	C	1
37	A	1
38	A	1
39	A	1
40	C	1



Cambridge IGCSE™

PHYSICS

0625/11

Paper 1 Multiple Choice (Core)

October/November 2020

45 minutes

You must answer on the multiple choice answer sheet.

You will need: Multiple choice answer sheet
Soft clean eraser
Soft pencil (type B or HB is recommended)

INSTRUCTIONS

- There are **forty** questions on this paper. Answer **all** questions.
- For each question there are four possible answers **A, B, C** and **D**. Choose the **one** you consider correct and record your choice in soft pencil on the multiple choice answer sheet.
- Follow the instructions on the multiple choice answer sheet.
- Write in soft pencil.
- Write your name, centre number and candidate number on the multiple choice answer sheet in the spaces provided unless this has been done for you.
- Do **not** use correction fluid.
- Do **not** write on any bar codes.
- You may use a calculator.
- Take the weight of 1.0 kg to be 10 N (acceleration of free fall = 10 m/s^2).

INFORMATION

- The total mark for this paper is 40.
- Each correct answer will score one mark. A mark will not be deducted for a wrong answer.
- Any rough working should be done on this question paper.

This document has **16** pages. Blank pages are indicated.



- 1 The diagram shows a pendulum. The pendulum bob swings repeatedly between points M and N.

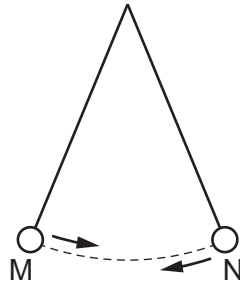

A student starts a stop-watch when the bob reaches point M.

He counts each time the bob changes direction and stops the watch on the tenth change in direction.

The watch shows a time of 12.0 seconds.

What is the period of the pendulum?

- A** 0.60 s **B** 1.2 s **C** 2.4 s **D** 12.0 s
- 2 The speed–time graph represents a journey.

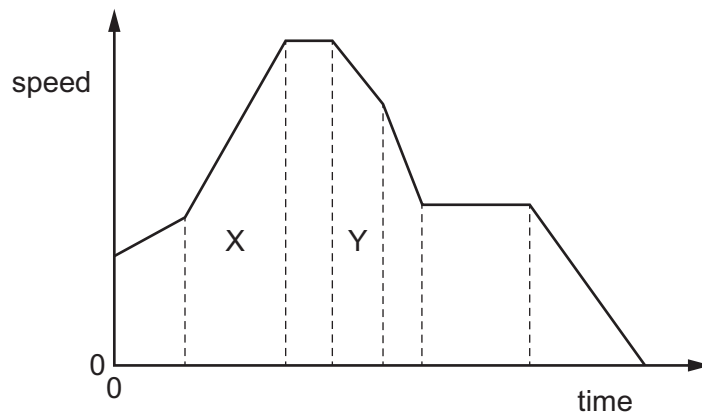

How does the graph show that the distance travelled in section X of the journey is greater than the distance travelled in section Y?

- A** The area below section X of the graph is greater than the area below section Y.
- B** The gradient of section X of the graph is greater than the gradient of section Y.
- C** The speed at the end of section X of the journey is greater than the speed at the end of section Y.
- D** The time for section X of the journey is greater than the time for section Y.

- 3 A boy throws a ball vertically upwards with a speed v .

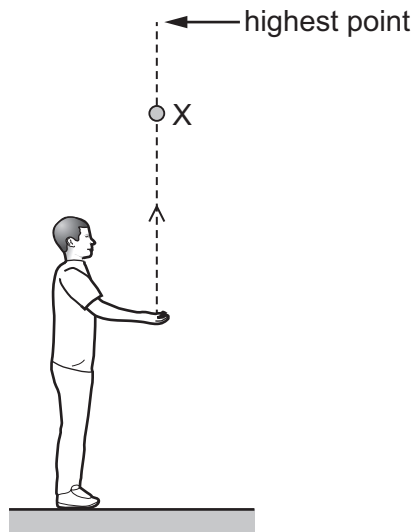

Which row describes the speed and the acceleration of the ball at point X on the way upwards?

	speed	acceleration
A	decreasing	upwards
B	decreasing	downwards
C	increasing	upwards
D	increasing	downwards

- 4 A student compares the weights of different objects.

Which apparatus does he use?

- A** balance
 - B** measuring cylinder
 - C** stop-watch
 - D** thermometer
- 5 Which quantity is weight an example of?
- A** acceleration
 - B** force
 - C** mass
 - D** pressure

- 6 A metal ball is attached to a cork and is lowered into a measuring cylinder, pulling the cork into the water, as shown.

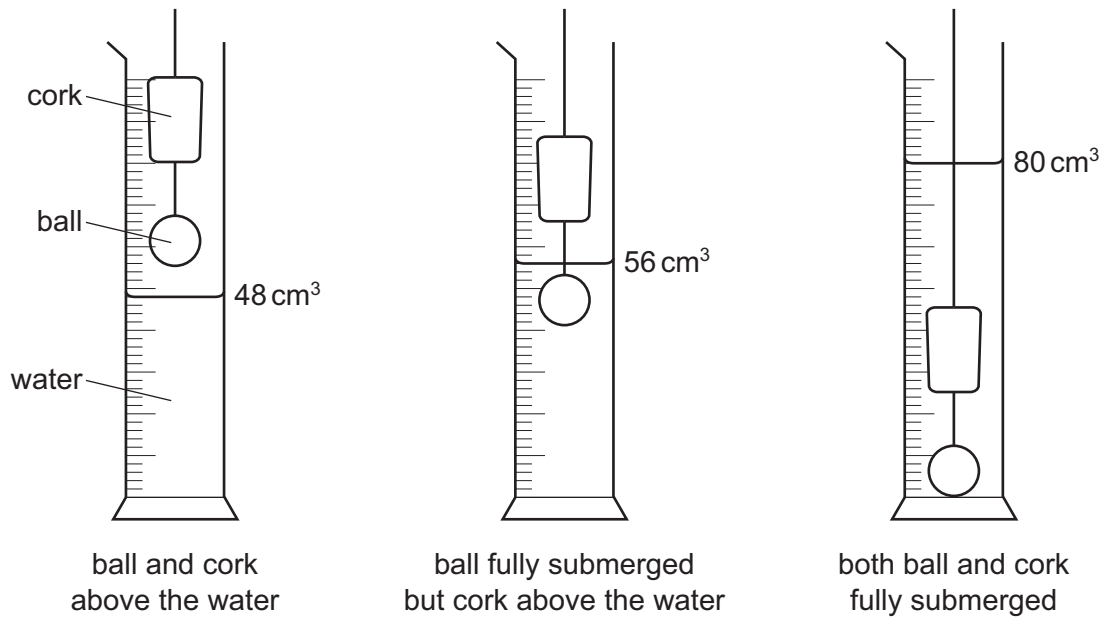

The mass of the cork is 4.8 g.

What is the density of the cork?

- A** 0.15 g/cm³ **B** 0.20 g/cm³ **C** 0.60 g/cm³ **D** 5.0 g/cm³
- 7 A uniform plank rests on a pivot at its centre.

Two children P and Q sit on the plank in the positions shown.

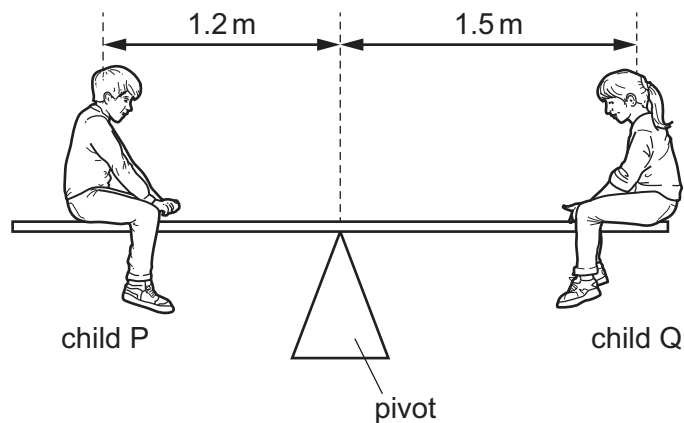

The mass of child P is 25 kg.

The plank is balanced.

What is the mass of child Q?

- A** 20 kg **B** 25 kg **C** 31 kg **D** 45 kg

8 An object is in equilibrium on the Earth.

Which statement is correct?

- A All the forces acting on the object are in the same direction.
- B All the forces acting on the object have the same value.
- C The object is weightless.
- D The resultant force acting on the object is zero.

9 A man jumps from a stationary balloon. After falling several hundred metres, he opens his parachute.

At which position is his kinetic energy greatest?

- A just after he jumps from the balloon
- B just before he opens his parachute
- C just after his parachute opens
- D just before he lands

10 The arrows show an outline of the processes in an oil-fired power station.

oil is burnt → turns turbine → turns generator → output transformer

What are the processes for the transfer of energy between the turbine and the generator and between the generator and the output transformer?

	turbine to generator	generator to output transformer
A	electrical working	electrical working
B	mechanical working	electrical working
C	mechanical working	transfer of thermal energy
D	transfer of thermal energy	mechanical working

11 To calculate the power produced by a force, the size of the force must be known.

What else needs to be known to calculate the power?

	the distance that the force moves the object	the time for which the force acts on the object
A	✓	✓
B	✓	x
C	x	✓
D	x	x

key

✓ = needed

x = not needed

12 A rectangular marble block has dimensions 1 m by 1 m by 5 m and weighs 125 000 N.

The marble block is stored with the long side resting on the ground, as in diagram 1.

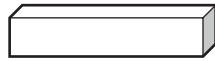

diagram 1



diagram 2

What is the change in the pressure on the ground due to the block when the block is stored as in diagram 2 rather than diagram 1?

- A a decrease of 25 000 Pa
- B an increase of 100 000 Pa
- C an increase of 125 000 Pa
- D no change

13 The diagram shows a mercury barometer.

Which height is used as a measurement of atmospheric pressure?

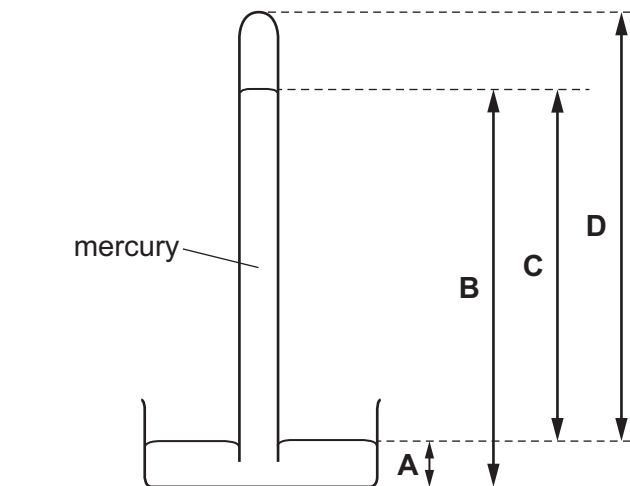

14 On a warm day, a driver checks the air pressure in a car tyre. At night, the temperature drops and the air pressure in the tyre decreases. There are no air leaks in the tyre.

Why does the pressure decrease?

- A The air molecules in the tyre move more slowly.
- B The air molecules in the tyre stop moving.
- C The volume of the air in the tyre decreases.
- D The volume of the air in the tyre increases.

- 15 The diagram shows the more energetic water molecules escaping from the surface of liquid water.

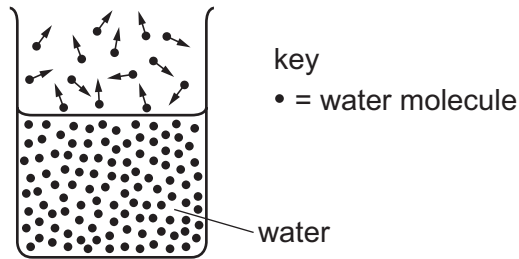

What is this process called?

- A Brownian motion
 - B condensation
 - C evaporation
 - D conduction
- 16 When a bridge is built, a gap is left between each concrete slab.

Why are these gaps left?

- A Concrete expands on warm days.
 - B Concrete contracts on warm days.
 - C The gaps expand on warm days.
 - D The gaps contract on cold days.
- 17 The table shows the melting and boiling points of four different substances.

Which substance becomes a liquid when placed in a beaker of boiling water?

	melting point/°C	boiling point/°C
A	10	90
B	40	150
C	105	230
D	110	320

18 The diagram shows four rods. Each rod is made of a different metal.

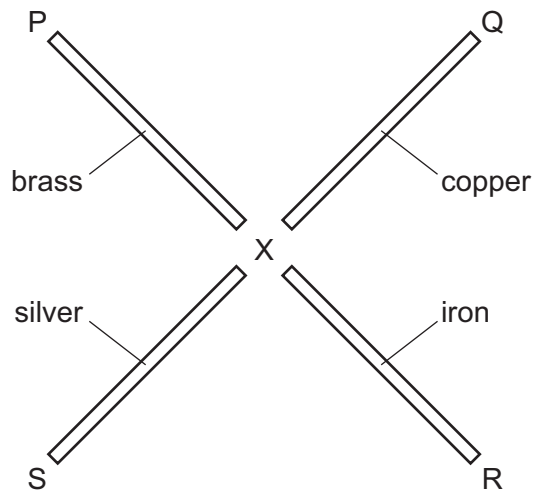

Wax is used to attach small metal balls at the rod ends P, Q, R and S.

Each rod is the same size. They are heated uniformly by a Bunsen burner at point X.

As the rods warm up, the wax melts and the balls fall off.

Why does the ball on the silver rod fall first?

- A Silver is the best conductor of heat.
- B Silver is the worst conductor of heat.
- C Silver is the best radiator of heat.
- D Silver is the worst radiator of heat.

19 The diagram shows a pan of water being heated.

After a short time, all the water in the pan begins to boil.

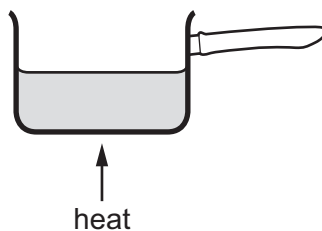

What is the main process by which thermal energy is transferred through the water?

- A conduction
- B convection
- C evaporation
- D radiation

20 Which row correctly describes light waves?

	wave type	direction of vibrations
A	longitudinal	parallel to direction of wave travel
B	longitudinal	perpendicular to direction of wave travel
C	transverse	parallel to direction of wave travel
D	transverse	perpendicular to direction of wave travel

21 The diagram shows two pieces of wood resting in shallow water of constant depth.

Straight, parallel wavefronts approach the pieces of wood as indicated.

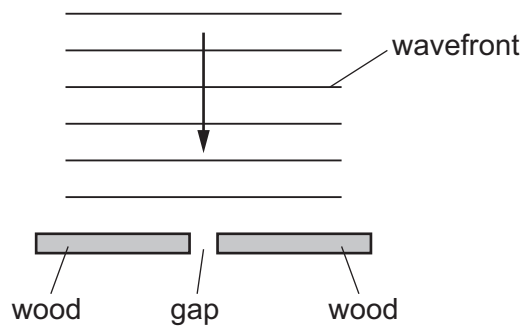

The gap between the pieces of wood is 2.0 cm wide.

The wavefronts are 3.0 cm apart.

What is the appearance of the wavefronts after they pass through the gap?

- A** semicircular and 2.0 cm apart
- B** semicircular and 3.0 cm apart
- C** straight and 2.0 cm apart
- D** straight and 3.0 cm apart

22 A man sees a stone at the bottom of a pool of water.

Which path could be taken by light from the stone to the man?

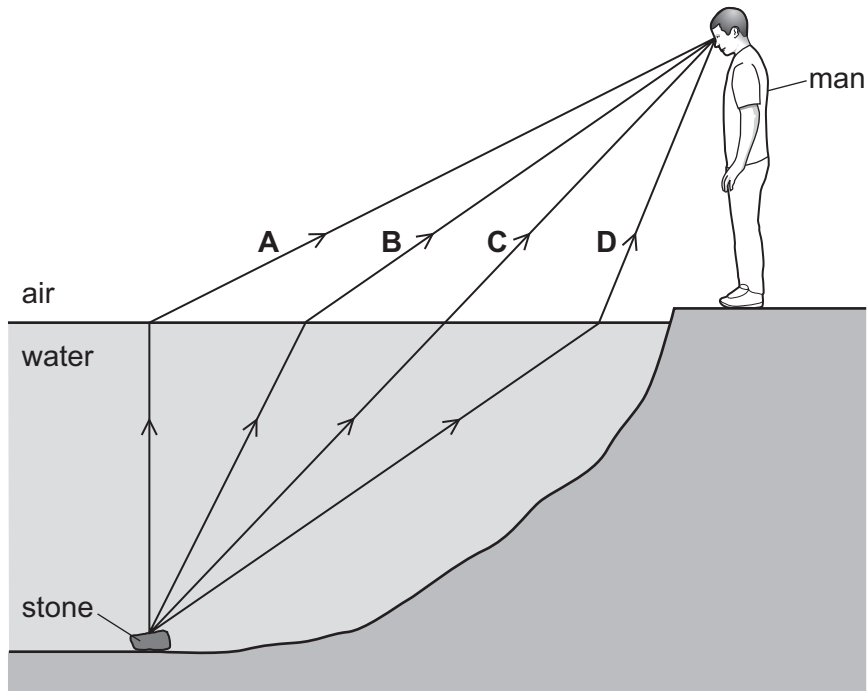

23 Which statement about a thin converging lens is correct?

- A All rays of light refracted by the lens pass through the principal focus.
- B All rays initially parallel to the principal axis of the lens are refracted through the principal focus.
- C The focal length of the lens is the distance between the image and the principal focus.
- D The focal length of the lens is the distance between the object and the image.

- 24 The diagram shows a beam of white light passing through a triangular prism. A spectrum is produced.

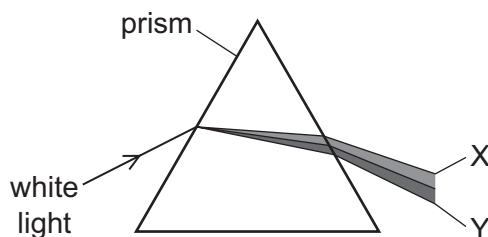

Which row correctly shows a wave property involved in producing the colours at X and Y?

	wave property	X	Y
A	diffraction	red	violet
B	dispersion	red	violet
C	reflection	violet	red
D	refraction	violet	red

- 25 The diagram shows the electromagnetic spectrum.

γ -rays	E	ultraviolet	F	infrared	microwaves	G
----------------	---	-------------	---	----------	------------	---

Which types of wave are E, F and G?

	E	F	G
A	radio	visible light	X-rays
B	radio	X-rays	ultrasound
C	X-rays	radio	ultrasound
D	X-rays	visible light	radio

- 26 A police car with its siren sounding is stationary in heavy traffic. A pedestrian notices that, although the loudness of the sound produced does not change, the pitch varies.

Which row describes the amplitude and the frequency of the sound?

	amplitude	frequency
A	constant	constant
B	constant	varying
C	varying	constant
D	varying	varying

27 Two soft-iron pins are suspended from the S pole of a bar magnet.

Which diagram shows how the pins are deflected?

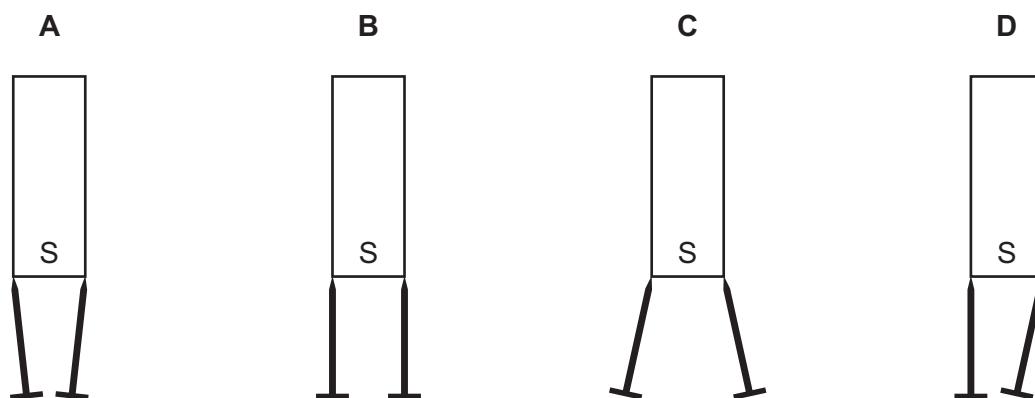

28 A student uses three small plotting compasses to investigate the magnetic field around a bar magnet.

Which diagram shows the directions in which the compass needles point?

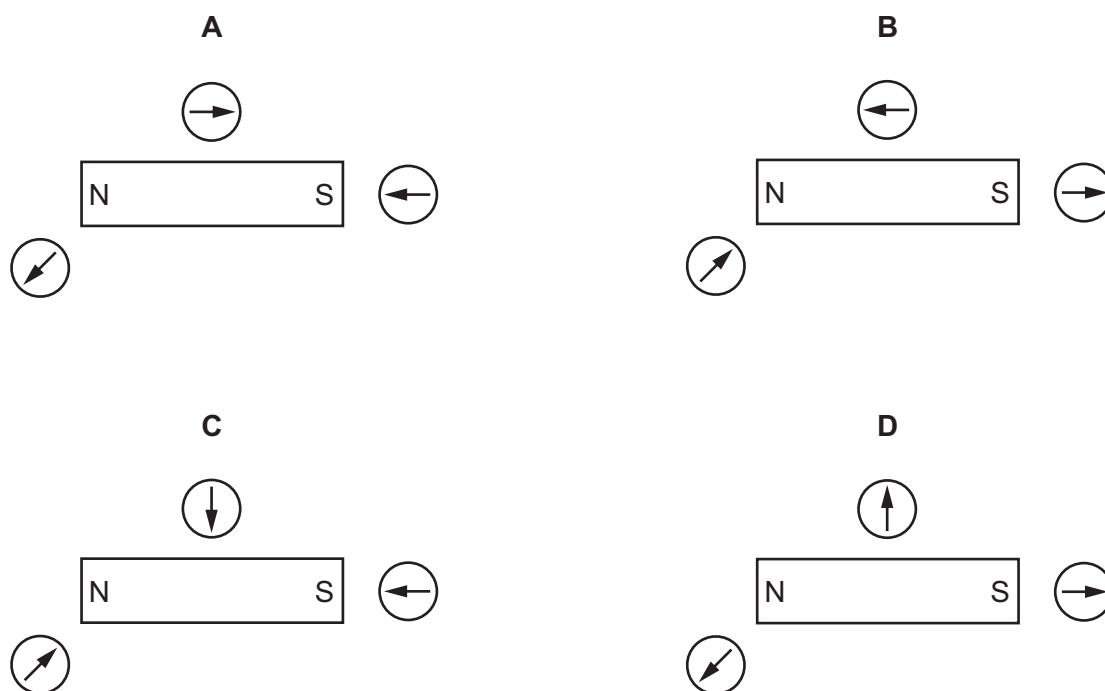

29 What is an electric current in a metal wire?

- A a flow of electrons
- B a flow of neutrons
- C a flow of nucleons
- D a flow of protons

30 Four wires are made of the same metal.

Which wire has the greatest resistance?

- A a 100 cm long wire with a diameter of 3.0 mm
- B a 100 cm long wire with a diameter of 6.0 mm
- C a 10 cm long wire with a diameter of 3.0 mm
- D a 10 cm long wire with a diameter of 6.0 mm

31 A student uses four ammeters P, Q, R and S to measure the current in different parts of the circuit shown.

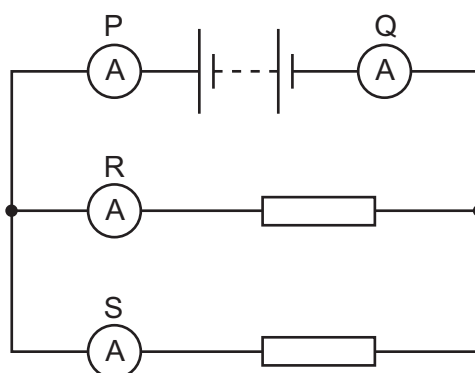

Which two ammeters read the largest current?

- A P and Q
- B P and R
- C R and Q
- D R and S

32 A circuit X is set up with two identical lamps. Circuit Y is then set up, changing the positions of the meters.

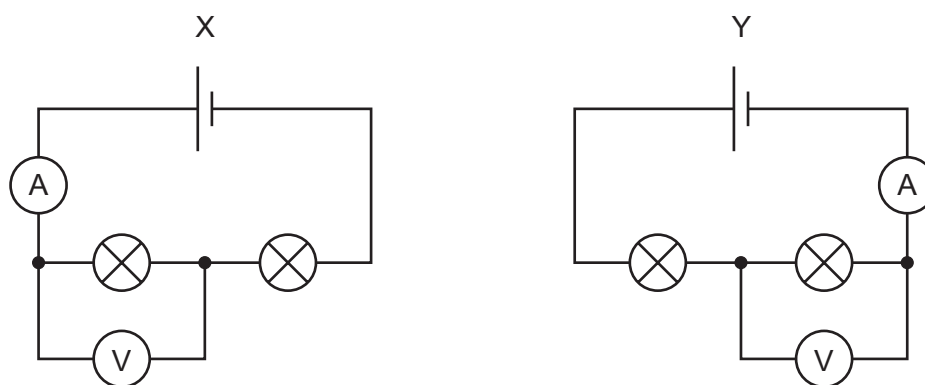

On which meters do the readings change?

- A both the ammeter and the voltmeter
- B the ammeter only
- C the voltmeter only
- D neither the ammeter nor the voltmeter

33 An electrical appliance is powered from a mains supply.

The appliance normally uses a current of 3 A, but the current briefly rises to 4 A at the instant the appliance is switched on. The cable to the appliance is designed for currents up to 6 A.

A fuse is used to protect the circuit.

What should be the rating of the fuse?

- A** 1 A **B** 3 A **C** 5 A **D** 13 A

34 An electromagnet is positioned close to a coil of wire.

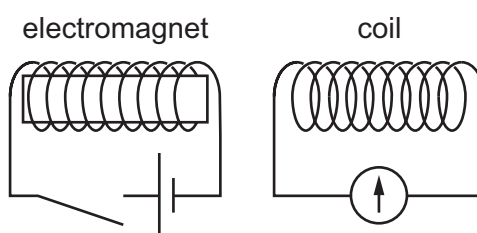

The electromagnet is switched on, remains on for a short time, and is then switched off.

Three statements about the pointer on the galvanometer during this sequence are given.

- 1 The pointer kicks to one side as the electromagnet is switched on.
- 2 The pointer records a steady non-zero value while the electromagnet remains switched on.
- 3 The pointer kicks to the other side as the electromagnet is switched off.

Which statements are correct?

- A** 1 and 2 only **B** 1 and 3 only **C** 2 and 3 only **D** 1, 2 and 3

35 A transformer is needed to convert a supply of 240 V a.c. into 4800 V a.c..

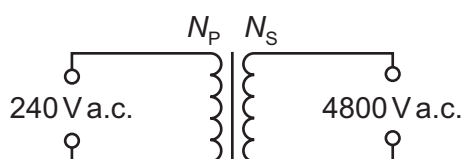

Which pair of coils would be suitable for this transformer?

	number of turns on primary coil N_p	number of turns on secondary coil N_s
A	50	1 000
B	240	48 000
C	480	24
D	2000	100

36 The diagrams show a current-carrying wire with an arrow in the direction of the current.

Which diagram shows the magnetic field produced by the current?

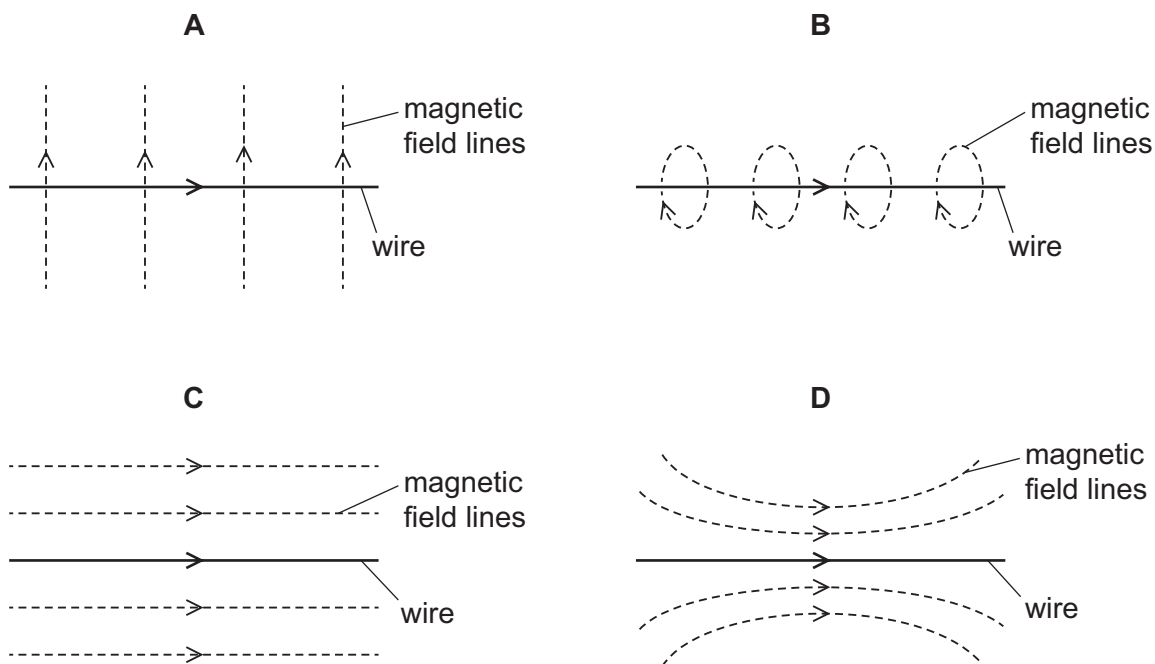

37 Which statement is correct for the nucleus of **any** atom?

- A The nucleus contains electrons, neutrons and protons.
- B The nucleus contains the same number of protons as neutrons.
- C The nucleus has a total charge of zero.
- D The nucleus is very small compared with the size of the atom.

38 The nucleus of an atom X is represented by the notation shown.



How many protons and how many neutrons are in this nucleus?

	number of protons	number of neutrons
A	P	Q
B	P	Q – P
C	Q	P
D	Q	P – Q

39 A radiation detector records a low reading even when no radioactive source is close. This is due to background radiation.

What does **not** contribute to this background radiation?

- A rocks on Earth
- B cosmic rays from the Sun
- C satellite TV signals
- D waste from nuclear power stations

40 The graph shows the radioactive decay curve of a substance.

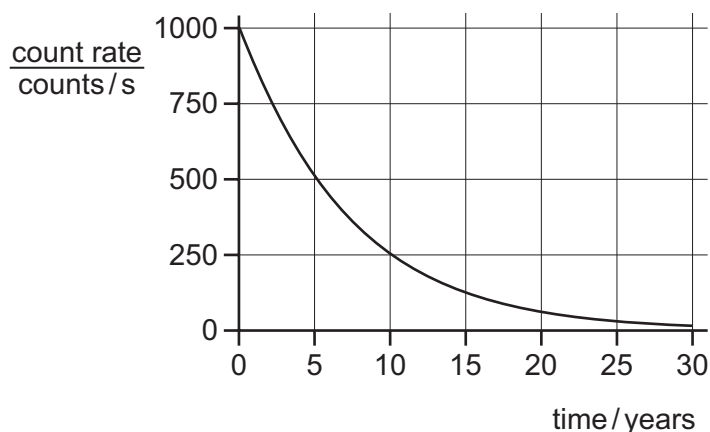

What is the half-life of this substance?

- A 0.5 years
- B 5 years
- C 15 years
- D 30 years

Permission to reproduce items where third-party owned material protected by copyright is included has been sought and cleared where possible. Every reasonable effort has been made by the publisher (UCLES) to trace copyright holders, but if any items requiring clearance have unwittingly been included, the publisher will be pleased to make amends at the earliest possible opportunity.

To avoid the issue of disclosure of answer-related information to candidates, all copyright acknowledgements are reproduced online in the Cambridge Assessment International Education Copyright Acknowledgements Booklet. This is produced for each series of examinations and is freely available to download at www.cambridgeinternational.org after the live examination series.

Cambridge Assessment International Education is part of the Cambridge Assessment Group. Cambridge Assessment is the brand name of the University of Cambridge Local Examinations Syndicate (UCLES), which itself is a department of the University of Cambridge.



Cambridge IGCSE™

PHYSICS

0625/11

Paper 1 Multiple Choice (Core)

October/November 2020

MARK SCHEME

Maximum Mark: 40

Published

This mark scheme is published as an aid to teachers and candidates, to indicate the requirements of the examination.

Mark schemes should be read in conjunction with the question paper and the Principal Examiner Report for Teachers.

Cambridge International will not enter into discussions about these mark schemes.

Cambridge International is publishing the mark schemes for the October/November 2020 series for most Cambridge IGCSE™, Cambridge International A and AS Level and Cambridge Pre-U components, and some Cambridge O Level components.

This document consists of **3** printed pages.

Question	Answer	Marks
1	C	1
2	A	1
3	B	1
4	A	1
5	B	1
6	B	1
7	A	1
8	D	1
9	B	1
10	B	1
11	A	1
12	B	1
13	C	1
14	A	1
15	C	1
16	A	1
17	B	1
18	A	1
19	B	1
20	D	1
21	B	1
22	B	1
23	B	1
24	B	1
25	D	1
26	B	1
27	C	1
28	A	1

Question	Answer	Marks
29	A	1
30	A	1
31	A	1
32	D	1
33	C	1
34	B	1
35	A	1
36	B	1
37	D	1
38	D	1
39	C	1
40	B	1



Cambridge IGCSE™

PHYSICS

0625/12

Paper 1 Multiple Choice (Core)

October/November 2020

45 minutes

You must answer on the multiple choice answer sheet.

You will need: Multiple choice answer sheet
Soft clean eraser
Soft pencil (type B or HB is recommended)

INSTRUCTIONS

- There are **forty** questions on this paper. Answer **all** questions.
- For each question there are four possible answers **A**, **B**, **C** and **D**. Choose the **one** you consider correct and record your choice in soft pencil on the multiple choice answer sheet.
- Follow the instructions on the multiple choice answer sheet.
- Write in soft pencil.
- Write your name, centre number and candidate number on the multiple choice answer sheet in the spaces provided unless this has been done for you.
- Do **not** use correction fluid.
- Do **not** write on any bar codes.
- You may use a calculator.
- Take the weight of 1.0 kg to be 10 N (acceleration of free fall = 10 m/s^2).

INFORMATION

- The total mark for this paper is 40.
- Each correct answer will score one mark. A mark will not be deducted for a wrong answer.
- Any rough working should be done on this question paper.

This document has **16** pages. Blank pages are indicated.



- 1 A student measures the volumes of three liquids using three different measuring cylinders.

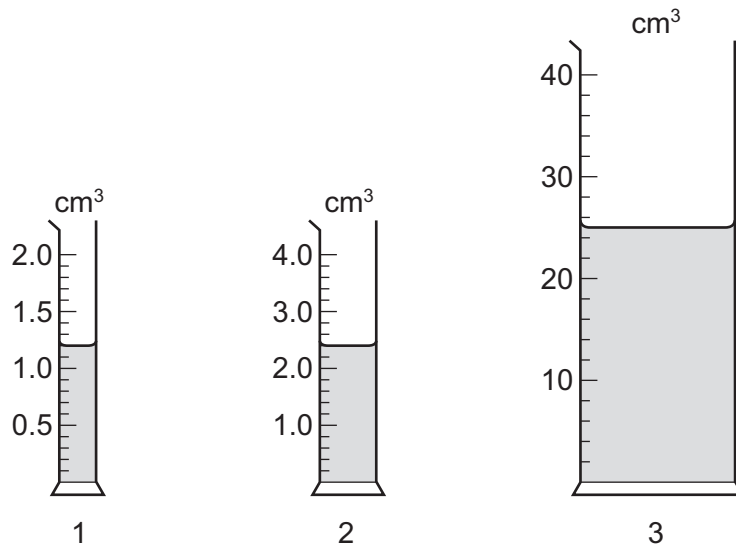

The table shows the volumes recorded by the student.

measuring cylinder	volume / cm ³
1	1.2
2	2.2
3	25

Which readings are correctly recorded?

- A** 1, 2 and 3 **B** 1 and 2 only **C** 1 and 3 only **D** 1 only

- 2 A car driver measures the time taken to complete four separate journeys.

In which journey does the driver have the greatest average speed?

	distance / km	time / h
A	60	2
B	60	3
C	120	3
D	120	4

- 3 The graph shows how the speed of an object varies with time.

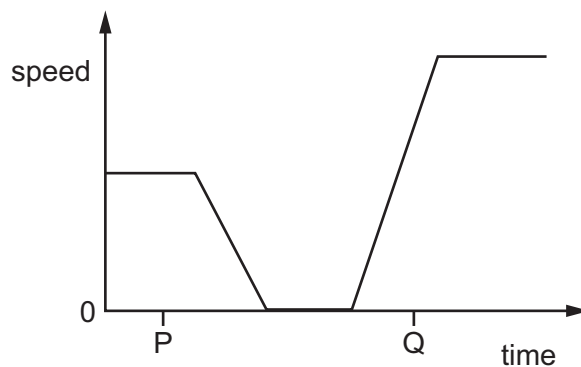

Which row describes the motion of the object at times P and Q?

	P	Q
A	at rest	accelerating
B	at rest	decelerating
C	moving with constant speed	accelerating
D	moving with constant speed	decelerating

- 4 A stone has a weight of 4.1 N.

What is the mass of the stone?

- A** 0.41 kg **B** 2.4 kg **C** 4.1 kg **D** 41 kg

- 5 Which quantity is weight an example of?

- A** acceleration
B force
C mass
D pressure

- 6 A rectangular metal block is 20 cm long.

The cross-sectional area of the block is 25 cm².

The mass of the block is 4000 g.

What is the density of the metal?

- A** 0.13 g/cm³ **B** 0.32 g/cm³ **C** 8.0 g/cm³ **D** 2000 g/cm³

- 7 A force of 4.0 N acts on a beam as shown.

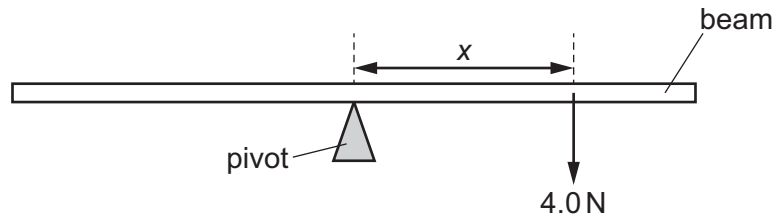

The line of action of the force is a distance x from a pivot. The moment of this force about this pivot is 8.0 N cm.

What is distance x ?

- A** 0.50 cm **B** 2.0 cm **C** 12 cm **D** 32 cm
- 8 The diagram shows a stand. The stand holds a heavy mass above the bench.

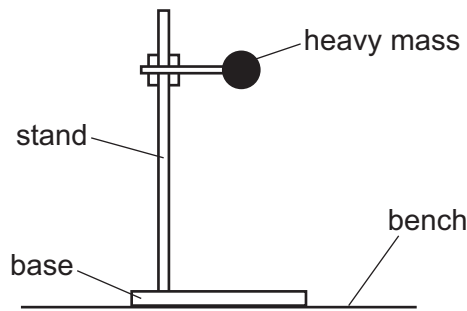

Which two changes would definitely make the stand more stable?

- A** Lower the mass and make the base narrower.
B Lower the mass and make the base wider.
C Raise the mass and make the base narrower.
D Raise the mass and make the base wider.
- 9 Two wind farms supply electrical energy to consumers in different ways.

Wind farm 1 supplies energy directly to consumers and for every 1000 J of energy extracted from the wind, 360 J is transferred to consumers as electrical energy.

Wind farm 2 stores electrical energy in batteries and then supplies energy from the batteries to the consumer. For every 1000 J of energy extracted from the wind, 270 J is transferred to consumers as electrical energy.

Which statement about the two wind farms is correct?

- A** Wind farm 1 is less reliable and less efficient than wind farm 2.
B Wind farm 1 is less reliable but more efficient than wind farm 2.
C Wind farm 1 is more reliable but less efficient than wind farm 2.
D Wind farm 1 is more reliable and more efficient than wind farm 2.

10 Work is done.

Which physical quantity is transferred?

- A distance
- B energy
- C force
- D temperature

11 To calculate the power produced by a force, the size of the force must be known.

What else needs to be known to calculate the power?

	the distance that the force moves the object	the time for which the force acts on the object
A	✓	✓
B	✓	x
C	x	✓
D	x	x

key

✓ = needed

x = not needed

12 The diagram shows a mercury barometer.

Which height is used as a measurement of atmospheric pressure?

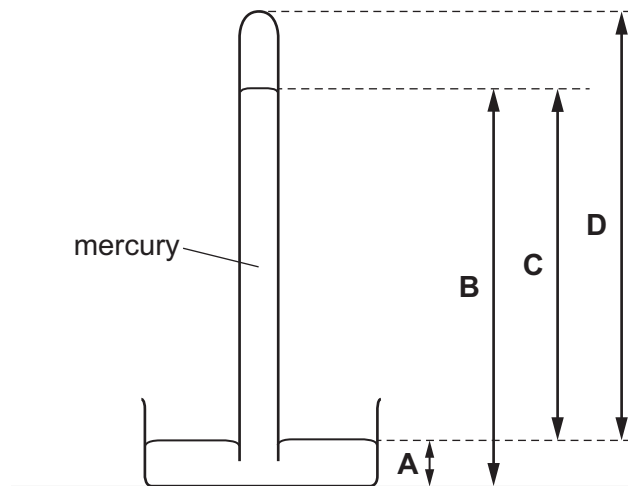

- 13** A man who weighs 540 N stands with both feet on the ground. The area of contact between one foot and the ground is 0.015 m^2 .

What is the pressure exerted on the floor by the man?

- A** 1800 N/m^2
 - B** 3600 N/m^2
 - C** 18000 N/m^2
 - D** 36000 N/m^2
- 14** On a warm day, a driver checks the air pressure in a car tyre. At night, the temperature drops and the air pressure in the tyre decreases. There are no air leaks in the tyre.

Why does the pressure decrease?

- A** The air molecules in the tyre move more slowly.
 - B** The air molecules in the tyre stop moving.
 - C** The volume of the air in the tyre decreases.
 - D** The volume of the air in the tyre increases.
- 15** Wet clothes are put out on a line to allow the water in the clothes to evaporate.

Which type of weather would cause the water to evaporate most quickly?

- A** a cold day with no wind
- B** a cold day with wind
- C** a hot day with no wind
- D** a hot day with wind

- 16 A bimetallic strip is used to control the temperature of electrical appliances. It is made of two different metals fixed together.

The diagram shows the shape of the bimetallic strip before and after heating.

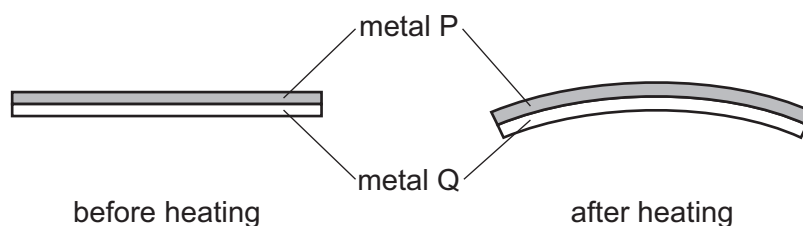

Which statement is correct?

- A Metal P contracts more than metal Q on heating.
 B Metal Q contracts more than metal P on heating.
 C Metal P expands more than metal Q on heating.
 D Metal Q expands more than metal P on heating.
- 17 Samples of four different substances are heated in turn by the same heater, for the same time duration and in the same conditions. The increase in temperature for each sample is recorded in the table.

Which sample has the highest thermal capacity?

	sample	temperature rise / °C
A	aluminium	6.0
B	copper	8.0
C	mercury	10.0
D	water	5.0

- 18 Thermal energy is supplied at the same rate to four bars made from different materials.



After several minutes, there is a temperature difference between X and Y for each bar.

Which statement identifies the bar with the greatest temperature difference between points X and Y, and gives the correct reason?

- A copper because it is a good conductor of thermal energy
 B lead because it is the densest metal
 C plastic because it is a poor conductor of thermal energy
 D wood because it is a good conductor of thermal energy

- 19 A scientist measures the air temperature at different heights from the floor in a cave. The results are recorded in the table.

height / m	temperature / °C
0	10
10	11
20	13
30	14
40	16

Why does altering the height affect the temperature of the air?

- A The molecules in warm air have less energy than the molecules in cool air.
- B The molecules in cool air are further apart than the molecules in warm air.
- C Warm air is less dense than cool air.
- D Cool air rises above warm air.

- 20 Which row correctly describes light waves?

	wave type	direction of vibrations
A	longitudinal	parallel to direction of wave travel
B	longitudinal	perpendicular to direction of wave travel
C	transverse	parallel to direction of wave travel
D	transverse	perpendicular to direction of wave travel

- 21 Waves travel across the surface of water.

What is meant by the amplitude of the wave?

- A the maximum distance of a water particle from its mean position
- B how far the wave travels every second
- C the number of waves passing a point every second
- D the distance between the top of consecutive waves

22 Which diagram shows the image correctly formed by reflection?

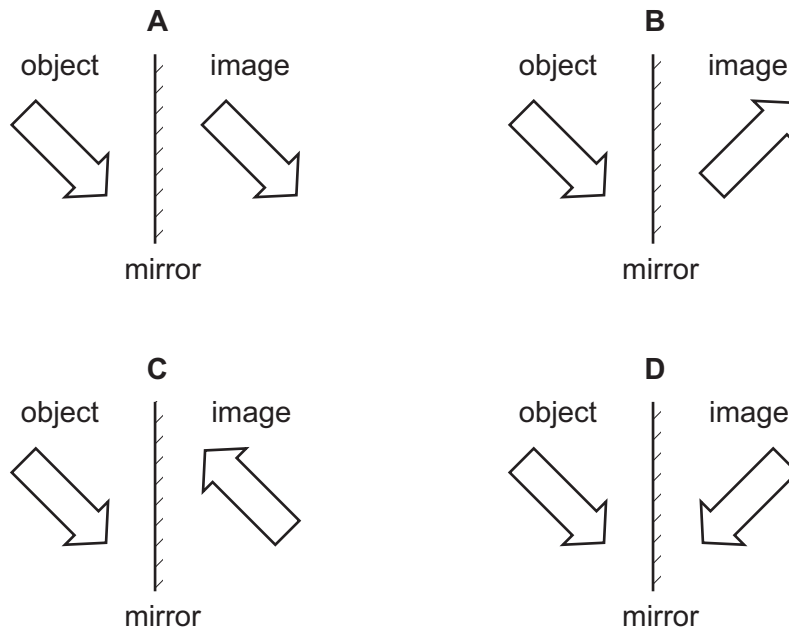

23 A man sees a stone at the bottom of a pool of water.

Which path could be taken by light from the stone to the man?

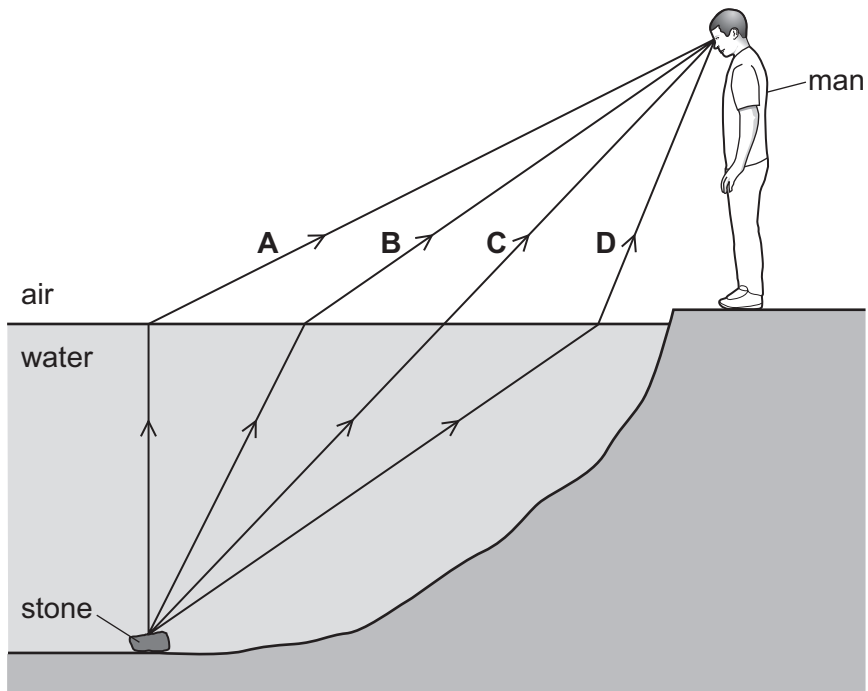

24 White light can be split into different colours by passing it through a prism.

What is the name of this process?

- A diffraction
- B dispersion
- C reflection
- D total internal reflection

25 Which type of radiation does a remote controller use to send its instructions to a TV set?

- A γ -rays
- B infrared radiation
- C ultraviolet radiation
- D X-rays

26 A police car with its siren sounding is stationary in heavy traffic. A pedestrian notices that, although the loudness of the sound produced does not change, the pitch varies.

Which row describes the amplitude and the frequency of the sound?

	amplitude	frequency
A	constant	constant
B	constant	varying
C	varying	constant
D	varying	varying

27 A student sets up four experiments using bar magnets and other metal objects. The N and S poles of the bar magnets are labelled N and S.

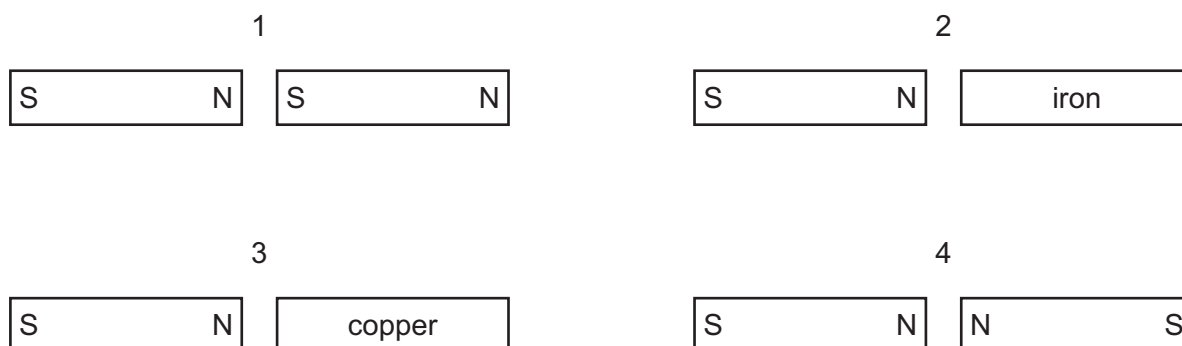

Which pairs attract each other?

- A 1 and 2
- B 1 and 3
- C 2 and 4
- D 3 and 4

- 28 A student uses three small plotting compasses to investigate the magnetic field around a bar magnet.

Which diagram shows the directions in which the compass needles point?

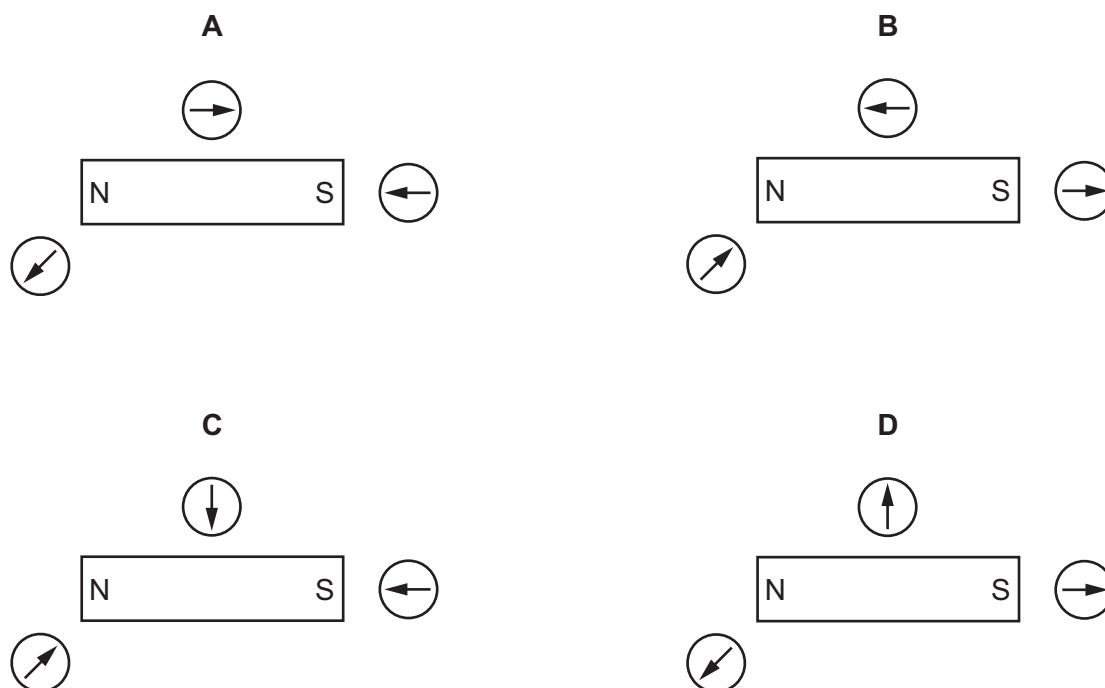

- 29 A polythene rod is charged negatively by rubbing it with a cloth.

Which statement explains why the rod has become charged?

- A The rod has gained electrons.
 - B The rod has gained protons.
 - C The rod has lost electrons.
 - D The rod has lost protons.
- 30 There is a current in a variable resistor when a potential difference (p.d.) is applied across it.
- In which situation is the current increased?
- A Decrease the p.d. and keep the resistance the same.
 - B Decrease the p.d. and increase the resistance.
 - C Keep the p.d. the same and decrease the resistance.
 - D Keep the p.d. the same and increase the resistance.

- 31 The circuit shown includes a battery, three lamps X, Y and Z and three switches S_1 , S_2 and S_3 .

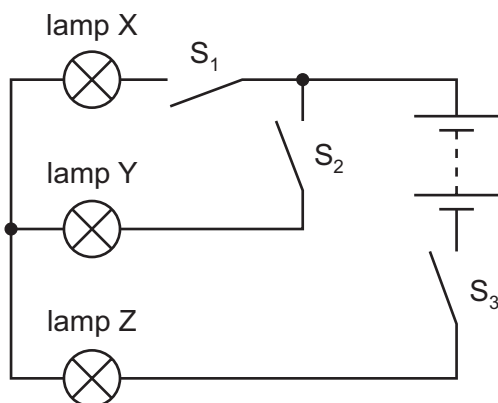

Lamp X is off but lamps Y and Z are lit.

Which switches are closed?

- A** S_1 and S_2 only
B S_1 and S_3 only
C S_2 and S_3 only
D S_1 , S_2 and S_3
- 32 A student uses four ammeters P, Q, R and S to measure the current in different parts of the circuit shown.

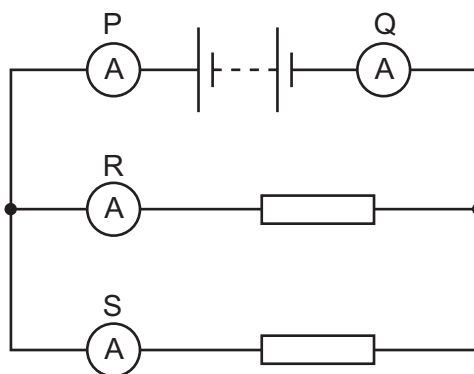

Which two ammeters read the largest current?

- A** P and Q **B** P and R **C** R and Q **D** R and S
- 33 An electrical appliance is powered from a mains supply.

The appliance normally uses a current of 3 A, but the current briefly rises to 4 A at the instant the appliance is switched on. The cable to the appliance is designed for currents up to 6 A.

A fuse is used to protect the circuit.

What should be the rating of the fuse?

- A** 1 A **B** 3 A **C** 5 A **D** 13 A

- 34 A student investigates electromagnetic induction. She moves the N pole of a magnet quickly towards a coil of wire. There is a reading on the galvanometer.

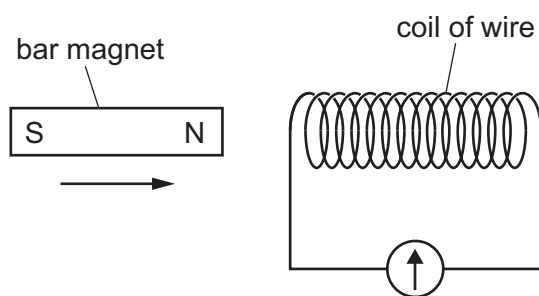

What can she do to get a greater reading on the galvanometer?

- A Hold the bar magnet stationary inside the coil.
 - B Move the bar magnet slowly away from the coil.
 - C Use a coil of wire with fewer turns on it.
 - D Use a stronger bar magnet.
- 35 A transformer is needed to convert a supply of 240 V a.c. into 4800 V a.c..

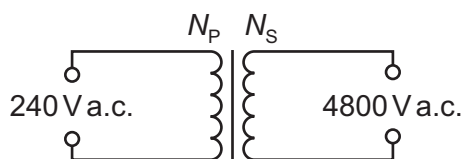

Which pair of coils would be suitable for this transformer?

	number of turns on primary coil N_P	number of turns on secondary coil N_S
A	50	1 000
B	240	48 000
C	480	24
D	2000	100

- 36 The diagram shows a wire carrying a current in the direction shown. The wire is between the poles of a magnet.

A force is produced on the wire out of the page.

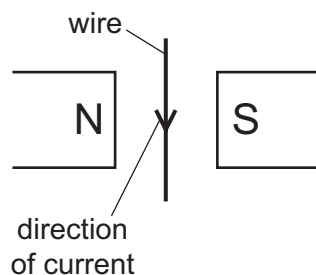

The wire and magnet are now put into different arrangements X, Y and Z. The arrow shows the direction of the current in each case.

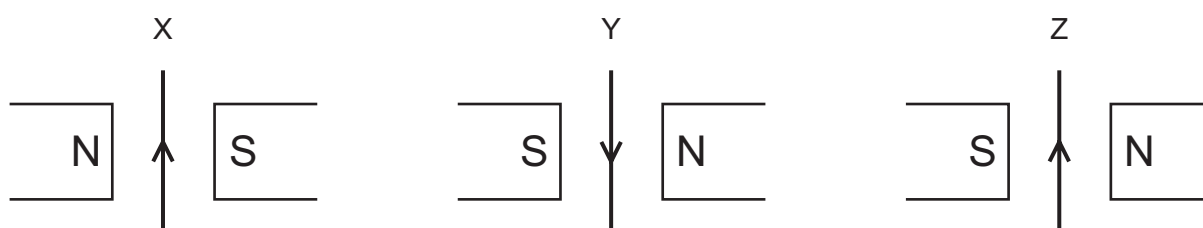

In which arrangements is the force on the wire out of the page?

- A X only B X and Y C X and Z D Z only
- 37 Which statement is correct for the nucleus of **any** atom?
- A The nucleus contains electrons, neutrons and protons.
 B The nucleus contains the same number of protons as neutrons.
 C The nucleus has a total charge of zero.
 D The nucleus is very small compared with the size of the atom.

- 38 The symbol represents a nucleus of zinc.



Which row gives the numbers of protons and neutrons in this nucleus?

	number of protons	number of neutrons
A	30	38
B	30	68
C	38	30
D	38	68

39 Three types of radiation are α -radiation, β -radiation and γ -radiation.

Which statement is correct?

- A α -radiation is less ionising than β -radiation.
- B α -radiation is less ionising than γ -radiation.
- C γ -radiation produces no ionisation.
- D β -radiation is more ionising than γ -radiation.

40 The graph shows the radioactive decay curve of a substance.

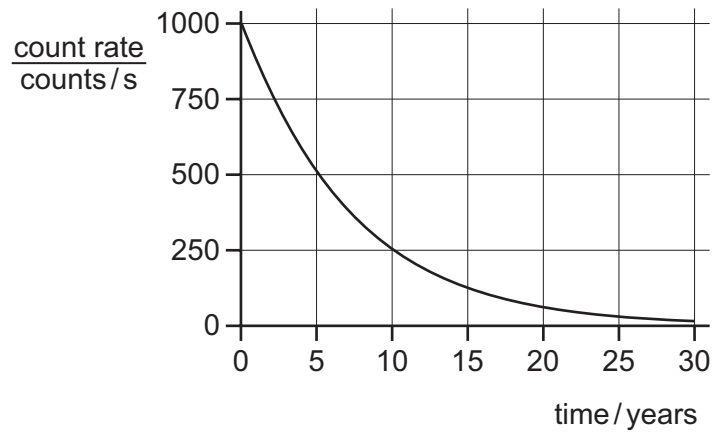

What is the half-life of this substance?

- A 0.5 years
- B 5 years
- C 15 years
- D 30 years

BLANK PAGE

Permission to reproduce items where third-party owned material protected by copyright is included has been sought and cleared where possible. Every reasonable effort has been made by the publisher (UCLES) to trace copyright holders, but if any items requiring clearance have unwittingly been included, the publisher will be pleased to make amends at the earliest possible opportunity.

To avoid the issue of disclosure of answer-related information to candidates, all copyright acknowledgements are reproduced online in the Cambridge Assessment International Education Copyright Acknowledgements Booklet. This is produced for each series of examinations and is freely available to download at www.cambridgeinternational.org after the live examination series.

Cambridge Assessment International Education is part of the Cambridge Assessment Group. Cambridge Assessment is the brand name of the University of Cambridge Local Examinations Syndicate (UCLES), which itself is a department of the University of Cambridge.



Cambridge IGCSE™

PHYSICS

0625/12

Paper 1 Multiple Choice (Core)

October/November 2020

MARK SCHEME

Maximum Mark: 40

Published

This mark scheme is published as an aid to teachers and candidates, to indicate the requirements of the examination.

Mark schemes should be read in conjunction with the question paper and the Principal Examiner Report for Teachers.

Cambridge International will not enter into discussions about these mark schemes.

Cambridge International is publishing the mark schemes for the October/November 2020 series for most Cambridge IGCSE™, Cambridge International A and AS Level and Cambridge Pre-U components, and some Cambridge O Level components.

This document consists of **3** printed pages.

Question	Answer	Marks
1	C	1
2	C	1
3	C	1
4	A	1
5	B	1
6	C	1
7	B	1
8	B	1
9	B	1
10	B	1
11	A	1
12	C	1
13	C	1
14	A	1
15	D	1
16	C	1
17	D	1
18	C	1
19	C	1
20	D	1
21	A	1
22	D	1
23	B	1
24	B	1
25	B	1
26	B	1
27	A	1
28	A	1

Question	Answer	Marks
29	A	1
30	C	1
31	C	1
32	A	1
33	C	1
34	D	1
35	A	1
36	D	1
37	D	1
38	A	1
39	D	1
40	B	1



Cambridge IGCSE™

PHYSICS

0625/13

Paper 1 Multiple Choice (Core)

October/November 2020

45 minutes

You must answer on the multiple choice answer sheet.

You will need: Multiple choice answer sheet
Soft clean eraser
Soft pencil (type B or HB is recommended)

INSTRUCTIONS

- There are **forty** questions on this paper. Answer **all** questions.
- For each question there are four possible answers **A, B, C** and **D**. Choose the **one** you consider correct and record your choice in soft pencil on the multiple choice answer sheet.
- Follow the instructions on the multiple choice answer sheet.
- Write in soft pencil.
- Write your name, centre number and candidate number on the multiple choice answer sheet in the spaces provided unless this has been done for you.
- Do **not** use correction fluid.
- Do **not** write on any bar codes.
- You may use a calculator.
- Take the weight of 1.0 kg to be 10 N (acceleration of free fall = 10 m/s^2).

INFORMATION

- The total mark for this paper is 40.
- Each correct answer will score one mark. A mark will not be deducted for a wrong answer.
- Any rough working should be done on this question paper.

This document has **16** pages. Blank pages are indicated.



1 A student uses a metre rule to measure the length of a sheet of paper.

Which measurement is shown to the nearest millimetre?

- A 0.3 m B 0.29 m C 0.293 m D 0.2932 m

2 The diagram shows the distance–time graph for the motion of an object.

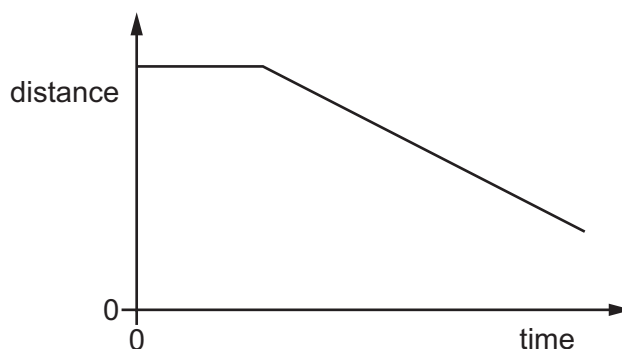

How can the motion of the object be described?

- A at rest, then constant deceleration
B at rest, then constant speed
C constant speed, then constant acceleration
D constant speed, then constant deceleration

3 An athlete runs 300 m up a hill in 100 s.

She then runs down the same hill in 50 s.

What is her average speed for the whole run?

- A 2.0 m/s B 4.0 m/s C 8.0 m/s D 9.0 m/s

- 4 The diagram shows an object on a balance. The reading on the balance is shown.

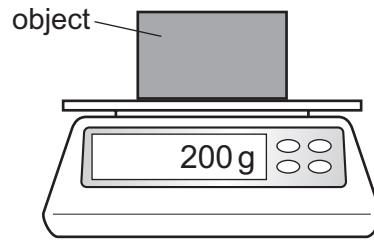

Which quantity is shown?

- A the mass of the object
 - B the pressure exerted by the object
 - C the volume of the object
 - D the weight of the object
- 5 Which quantity is weight an example of?
- A acceleration
 - B force
 - C mass
 - D pressure
- 6 A student is asked to predict whether a solid floats in a liquid.
- Which information does the student require?
- A the density of the liquid and the mass of the solid
 - B the density of the solid and the density of the liquid
 - C the density of the solid and the mass of the liquid
 - D the mass of the solid and the mass of the liquid

- 7 The diagram shows a car moving along a road.

The force due to the engine is 1500 N and the total drag force is 200 N.

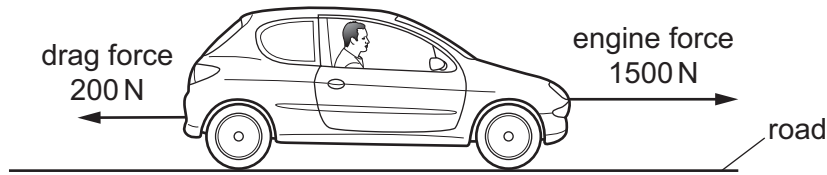

What is the motion of the car?

- A constant speed
 - B decreasing speed
 - C increasing speed
 - D reversing
- 8 Students X and Y are sitting on a seesaw. Student X has a weight of 400 N and student Y has a weight of 600 N. The seesaw is in equilibrium.

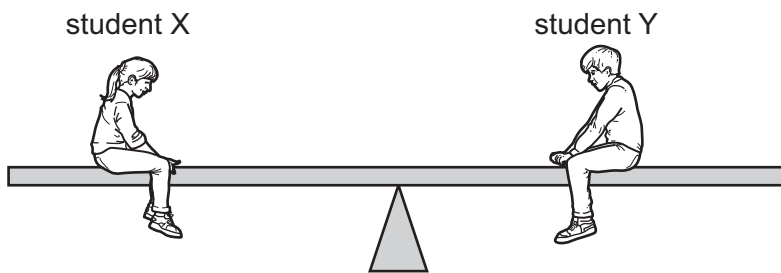

Which statement correctly describes why the seesaw is in equilibrium?

- A The resultant force is zero and the resultant moment is zero.
- B The resultant force is 200 N and the resultant moment is zero.
- C The sum of the downward forces is zero and the resultant moment is zero.
- D The total downward force is 1000 N and the resultant moment is 200 N m.

- 9 The diagram shows a frictionless pendulum.

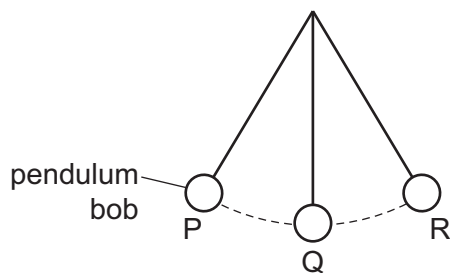

The pendulum bob swings from point P through point Q to point R then back to P.

At which point is the energy of the pendulum bob greatest?

- A** at point P
- B** at point Q
- C** at point R
- D** it is the same at points P, Q and R
- 10 Which statement correctly compares the production of electricity using wind and the production of electricity using nuclear fission?
- A** Wind is less reliable than nuclear fission; both wind and nuclear fission are renewable.
- B** Wind is less reliable than nuclear fission; wind is renewable, but nuclear fission is not.
- C** Wind is more reliable than nuclear fission; both wind and nuclear fission are renewable.
- D** Wind is more reliable than nuclear fission; wind is renewable, but nuclear fission is not.
- 11 To calculate the power produced by a force, the size of the force must be known.

What else needs to be known to calculate the power?

	the distance that the force moves the object	the time for which the force acts on the object
A	✓	✓
B	✓	✗
C	✗	✓
D	✗	✗

key

✓ = needed

✗ = not needed

12 The diagram shows a mercury barometer.

Which height is used as a measurement of atmospheric pressure?

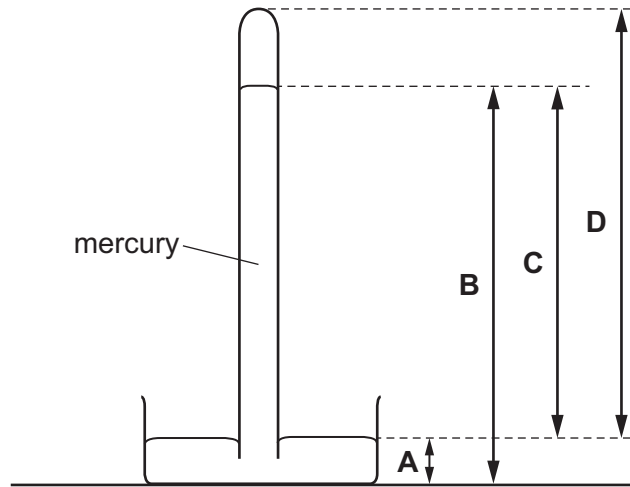

13 A large box has a weight of 700 N. The box is placed on the floor.

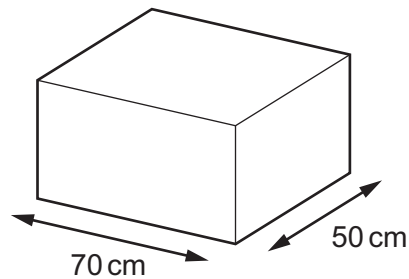

What is the pressure on the floor due to the box?

- A 0.20 N/m^2 B 10 N/m^2 C 245 N/m^2 D 2000 N/m^2

14 On a warm day, a driver checks the air pressure in a car tyre. At night, the temperature drops and the air pressure in the tyre decreases. There are no air leaks in the tyre.

Why does the pressure decrease?

- A The air molecules in the tyre move more slowly.
 B The air molecules in the tyre stop moving.
 C The volume of the air in the tyre decreases.
 D The volume of the air in the tyre increases.

- 15 A textbook gives the description of a thermal process as 'more-energetic molecules escape from the surface of a liquid which causes the liquid to cool'.

Which process is being described?

- A boiling
 - B Brownian motion
 - C condensation
 - D evaporation
- 16 Which physical property changes when temperature is measured with a liquid-in-glass thermometer?
- A electromotive force
 - B pressure
 - C resistance
 - D volume
- 17 Two different pure substances X and Y are heated. Both substance X and substance Y are initially in the solid state.

The graph shows how the temperature of each substance changes with time.

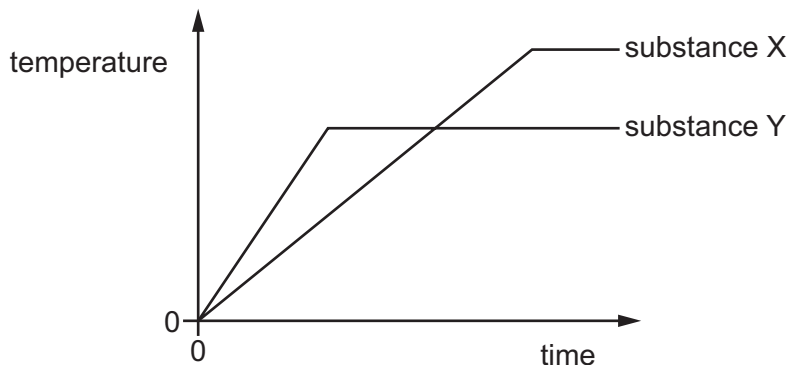

What does the graph tell us about the substances?

- A Substance X has a lower boiling point than substance Y.
- B Substance X has a lower melting point than substance Y.
- C Substance Y has a lower boiling point than substance X.
- D Substance Y has a lower melting point than substance X.

- 18 The diagram shows the view of a room heated by a radiator. The arrowed line from X to Y is the path of the convection current in the air.

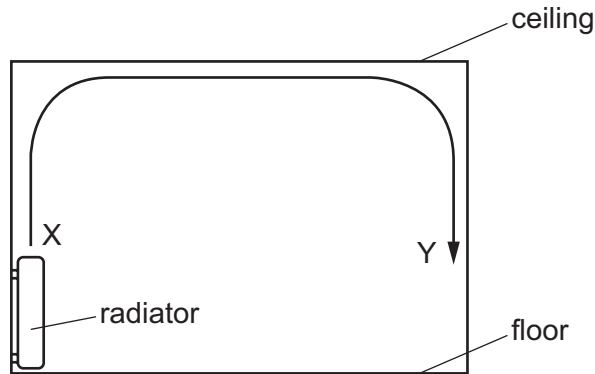

Which row about the air temperature and the air density at X and at Y is correct?

	air temperature	air density
A	higher at X	higher at X
B	higher at X	higher at Y
C	higher at Y	higher at Y
D	higher at Y	higher at X

- 19 Which thermal process can transfer energy through a vacuum?

- A** conduction
- B** convection
- C** evaporation
- D** radiation

- 20 Which row correctly describes light waves?

	wave type	direction of vibrations
A	longitudinal	parallel to direction of wave travel
B	longitudinal	perpendicular to direction of wave travel
C	transverse	parallel to direction of wave travel
D	transverse	perpendicular to direction of wave travel

21 The diagram shows a wave. It is not drawn to scale.

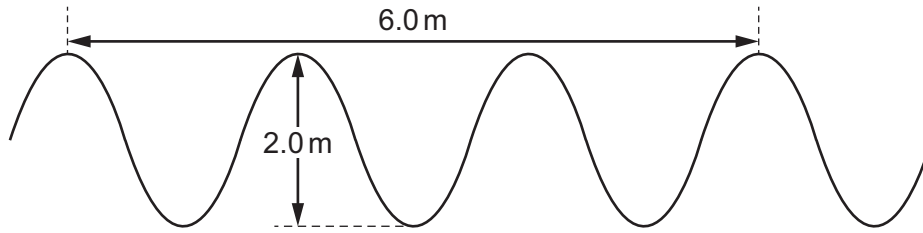

What are the amplitude and the wavelength of the wave?

	amplitude / m	wavelength / m
A	1.0	1.0
B	1.0	2.0
C	2.0	2.0
D	2.0	3.0

22 A boy is having his eyes tested. A letter is printed on a card placed over his head. He sees the card in a plane mirror placed on the far wall of the room.

He sees the letter 'R' in the mirror.

How is it printed on the card?



23 A man sees a stone at the bottom of a pool of water.

Which path could be taken by light from the stone to the man?

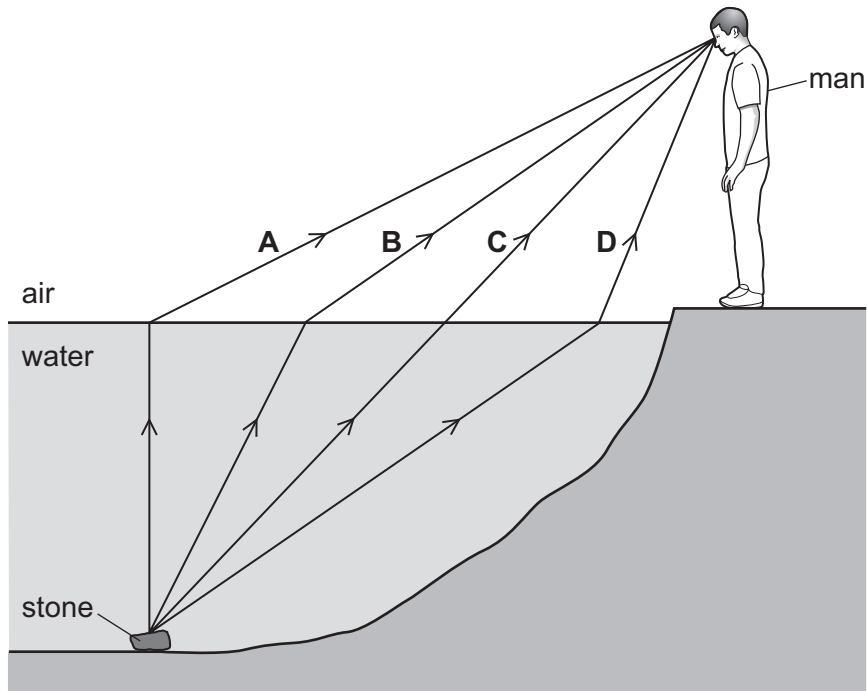

24 The diagram shows the image made by a converging lens.

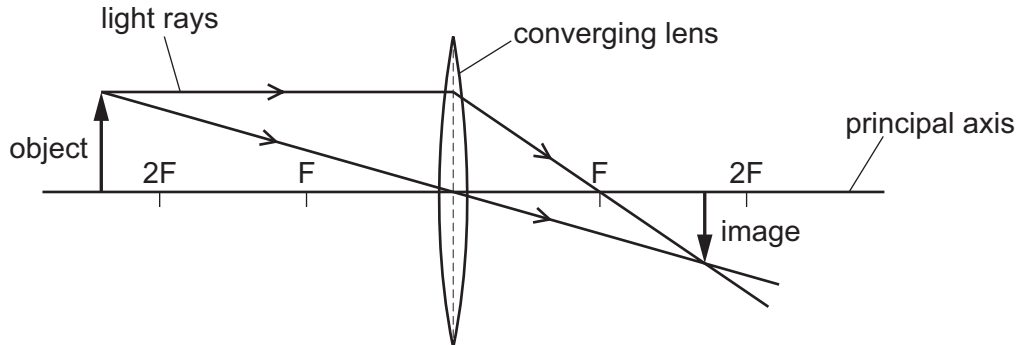

Which statement describes the image formed?

- A diminished and inverted
- B diminished and upright
- C enlarged and inverted
- D enlarged and upright

- 25 The diagram shows three types of electromagnetic radiation listed in a particular order. The electromagnetic radiation is travelling in a vacuum.



Which quantities increase in magnitude going from left to right across the list?

- A** frequency only
- B** neither speed nor frequency
- C** speed and frequency
- D** speed only
- 26 A police car with its siren sounding is stationary in heavy traffic. A pedestrian notices that, although the loudness of the sound produced does not change, the pitch varies.

Which row describes the amplitude and the frequency of the sound?

	amplitude	frequency
A	constant	constant
B	constant	varying
C	varying	constant
D	varying	varying

27 Diagrams 1, 2 and 3 show an experiment to compare two magnets 1 and 2.

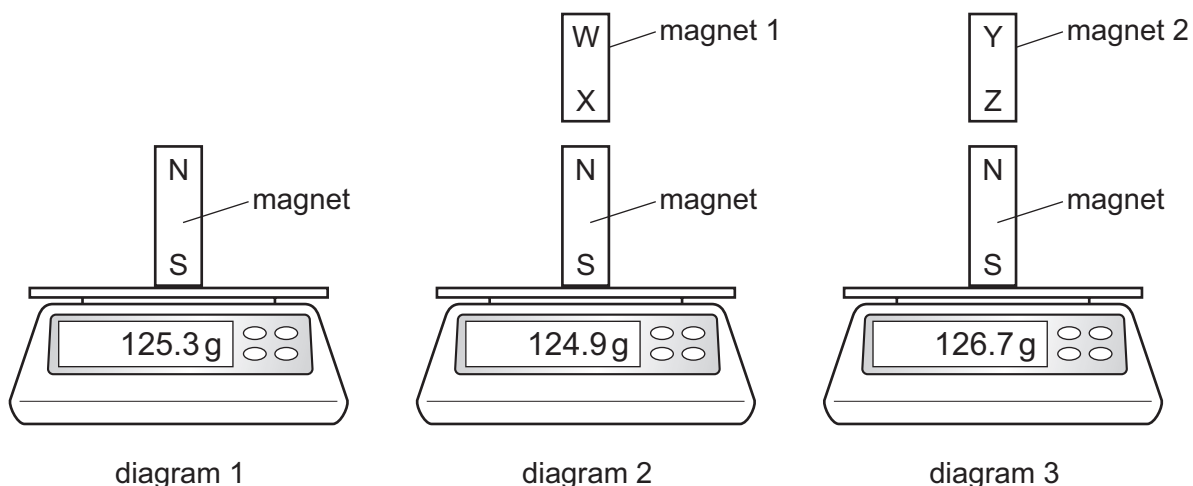

Which row explains the readings on the balances?

	polarity of magnet 1	polarity of magnet 2
A	X is an N pole	Z is an N pole
B	X is an N pole	Z is an S pole
C	X is an S pole	Z is an N pole
D	X is an S pole	Z is an S pole

28 A student uses three small plotting compasses to investigate the magnetic field around a bar magnet.

Which diagram shows the directions in which the compass needles point?

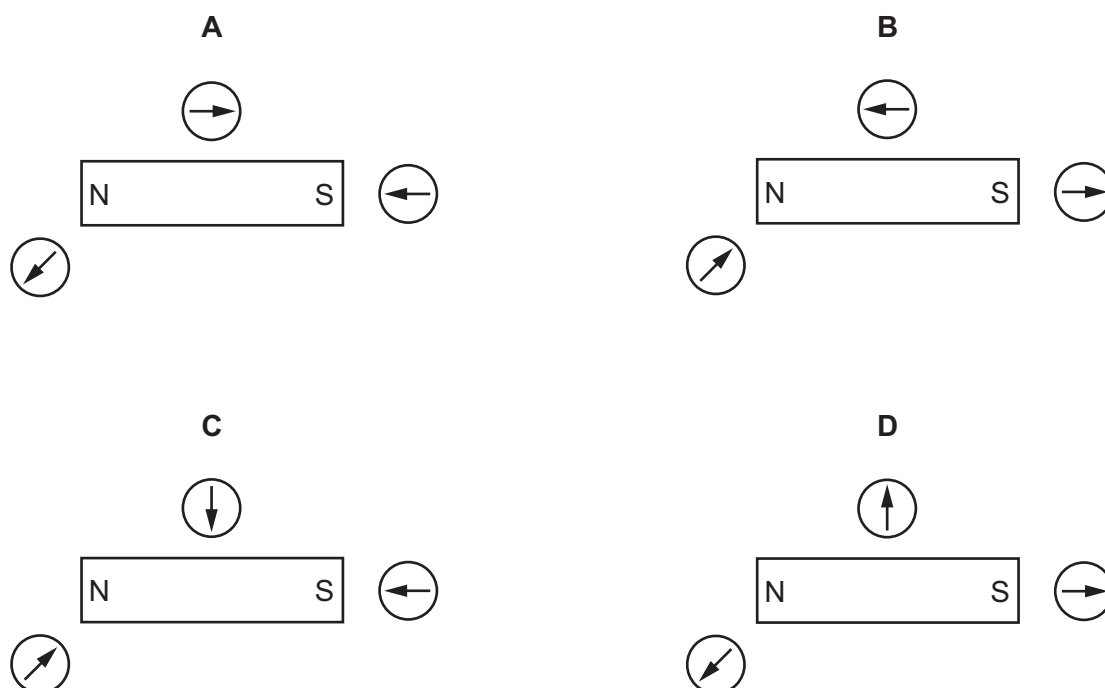

29 Which statement about charging an insulator is correct?

- A It can be given an electrostatic charge by placing it in a magnetic field.
- B It can be given an electrostatic charge by connecting it to a battery.
- C It can be given an electrostatic charge by friction.
- D It cannot be given an electrostatic charge.

30 Each diagram shows part of a circuit. The circle represents an instrument used to measure the potential difference (p.d.) across the resistor.

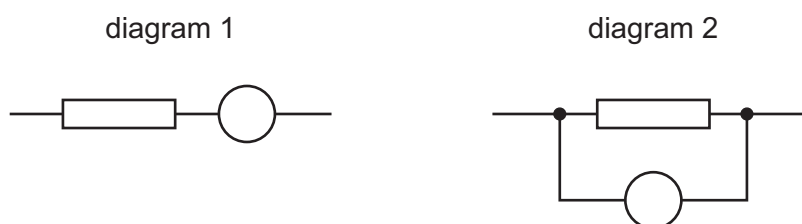

Which row is correct?

	the unit of p.d.	diagram which shows the meter correctly connected
A	amperes	diagram 1
B	amperes	diagram 2
C	volts	diagram 1
D	volts	diagram 2

31 A student uses four ammeters P, Q, R and S to measure the current in different parts of the circuit shown.

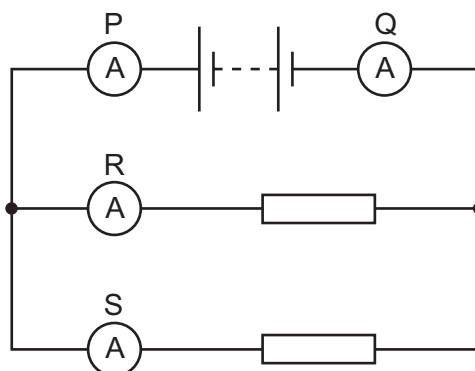

Which two ammeters read the largest current?

- A** P and Q
- B** P and R
- C** R and Q
- D** R and S

32 Three statements about a relay are given.

- 1 A relay has a coil that becomes a temporary magnet when in operation.
- 2 A large current in a relay coil is used to switch off a smaller current.
- 3 A small current in a relay coil is used to switch on a larger current.

Which statements are correct?

- A** 1 and 2 only **B** 2 and 3 only **C** 1 and 3 only **D** 1, 2 and 3

33 An electrical appliance is powered from a mains supply.

The appliance normally uses a current of 3 A, but the current briefly rises to 4 A at the instant the appliance is switched on. The cable to the appliance is designed for currents up to 6 A.

A fuse is used to protect the circuit.

What should be the rating of the fuse?

- A** 1 A **B** 3 A **C** 5 A **D** 13 A

34 When a metal wire moves up, cutting a magnetic field, an electromotive force (e.m.f.) is induced across the wire.

Which change affects the magnitude of the induced e.m.f.?

- A** moving the wire down at the same speed
B moving the wire up at a faster speed
C using a thicker wire
D using a wire made from a different metal

35 A transformer is needed to convert a supply of 240 V a.c. into 4800 V a.c..

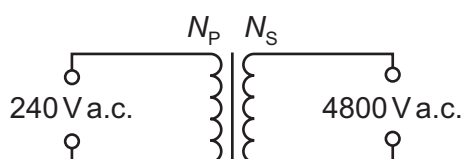

Which pair of coils would be suitable for this transformer?

	number of turns on primary coil N_p	number of turns on secondary coil N_s
A	50	1 000
B	240	48 000
C	480	24
D	2000	100

- 36 The diagram shows a wire carrying a current in the direction shown. There is a magnetic field acting from left to right. The wire experiences a force acting out of the page.

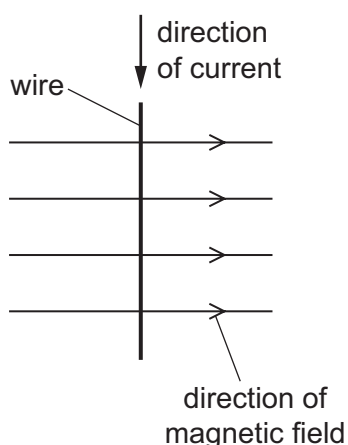

The current is now reversed.

In which direction does the force on the wire now act?

- A into the page
 B out of the page
 C to the left
 D to the right
- 37 Which statement is correct for the nucleus of **any** atom?
- A The nucleus contains electrons, neutrons and protons.
 B The nucleus contains the same number of protons as neutrons.
 C The nucleus has a total charge of zero.
 D The nucleus is very small compared with the size of the atom.
- 38 How many protons and how many neutrons are in a nucleus of ${}_{90}^{234}\text{Th}$?

	protons	neutrons
A	90	144
B	90	234
C	144	90
D	234	90

39 A radiation detector in a laboratory is measuring background radiation.

Which row describes the readings and the cause?

	readings	cause
A	vary with no pattern	background radiation is random
B	vary with no pattern	radiation detectors are unstable
C	slowly increase during the day	background radiation increases as temperature increases
D	slowly reduce during the day	background radiation decreases as temperature increases

40 The graph shows the radioactive decay curve of a substance.

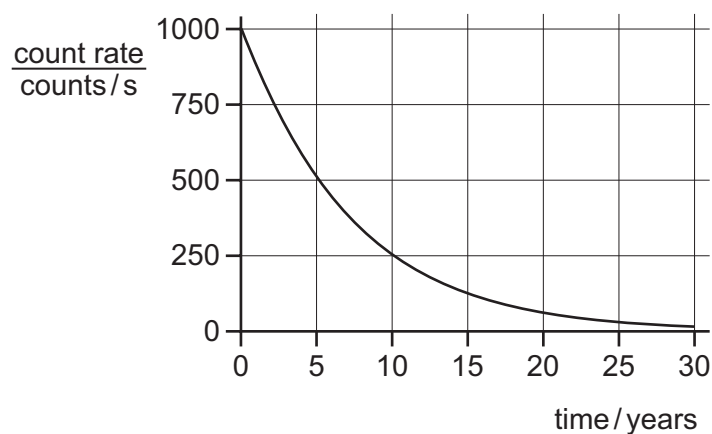

What is the half-life of this substance?

- A** 0.5 years **B** 5 years **C** 15 years **D** 30 years

Permission to reproduce items where third-party owned material protected by copyright is included has been sought and cleared where possible. Every reasonable effort has been made by the publisher (UCLES) to trace copyright holders, but if any items requiring clearance have unwittingly been included, the publisher will be pleased to make amends at the earliest possible opportunity.

To avoid the issue of disclosure of answer-related information to candidates, all copyright acknowledgements are reproduced online in the Cambridge Assessment International Education Copyright Acknowledgements Booklet. This is produced for each series of examinations and is freely available to download at www.cambridgeinternational.org after the live examination series.

Cambridge Assessment International Education is part of the Cambridge Assessment Group. Cambridge Assessment is the brand name of the University of Cambridge Local Examinations Syndicate (UCLES), which itself is a department of the University of Cambridge.



Cambridge IGCSE™

PHYSICS

0625/13

Paper 1 Multiple Choice (Core)

October/November 2020

MARK SCHEME

Maximum Mark: 40

Published

This mark scheme is published as an aid to teachers and candidates, to indicate the requirements of the examination.

Mark schemes should be read in conjunction with the question paper and the Principal Examiner Report for Teachers.

Cambridge International will not enter into discussions about these mark schemes.

Cambridge International is publishing the mark schemes for the October/November 2020 series for most Cambridge IGCSE™, Cambridge International A and AS Level and Cambridge Pre-U components, and some Cambridge O Level components.

This document consists of **3** printed pages.

Question	Answer	Marks
1	C	1
2	B	1
3	B	1
4	A	1
5	B	1
6	B	1
7	C	1
8	A	1
9	D	1
10	B	1
11	A	1
12	C	1
13	D	1
14	A	1
15	D	1
16	D	1
17	D	1
18	B	1
19	D	1
20	D	1
21	B	1
22	B	1
23	B	1
24	A	1
25	A	1
26	B	1
27	C	1
28	A	1

Question	Answer	Marks
29	C	1
30	D	1
31	A	1
32	C	1
33	C	1
34	B	1
35	A	1
36	A	1
37	D	1
38	A	1
39	A	1
40	B	1

A Topical Questions Tracker

A.1 Motion, forces and energy

A.1.1 Physical quantities and measurement techniques

0625_m20_qp_12	Question: 1	QP Page: 5	MS Page: 26
0625_s20_qp_11	Question: 1	QP Page: 30	MS Page: 51
0625_s20_qp_12	Question: 1	QP Page: 55	MS Page: 76
0625_s20_qp_13	Question: 1	QP Page: 80	MS Page: 101
0625_w20_qp_11	Question: 1	QP Page: 105	MS Page: 122
0625_w20_qp_12	Question: 1	QP Page: 126	MS Page: 143
0625_w20_qp_13	Question: 1	QP Page: 147	MS Page: 164

A.1.2 Motion

0625_m20_qp_12	Question: 2	QP Page: 5	MS Page: 26
0625_m20_qp_12	Question: 3	QP Page: 6	MS Page: 26
0625_s20_qp_11	Question: 2	QP Page: 30	MS Page: 51
0625_s20_qp_11	Question: 3	QP Page: 30	MS Page: 51
0625_s20_qp_12	Question: 2	QP Page: 55	MS Page: 76
0625_s20_qp_12	Question: 3	QP Page: 55	MS Page: 76
0625_s20_qp_13	Question: 2	QP Page: 80	MS Page: 101
0625_s20_qp_13	Question: 3	QP Page: 81	MS Page: 101
0625_w20_qp_11	Question: 2	QP Page: 105	MS Page: 122
0625_w20_qp_11	Question: 3	QP Page: 106	MS Page: 122
0625_w20_qp_12	Question: 2	QP Page: 126	MS Page: 143
0625_w20_qp_12	Question: 3	QP Page: 127	MS Page: 143
0625_w20_qp_13	Question: 2	QP Page: 147	MS Page: 164
0625_w20_qp_13	Question: 3	QP Page: 147	MS Page: 164

A.1.3 Mass and weight

0625_m20_qp_12	Question: 4	QP Page: 6	MS Page: 26
0625_m20_qp_12	Question: 5	QP Page: 6	MS Page: 26
0625_s20_qp_11	Question: 4	QP Page: 31	MS Page: 51
0625_s20_qp_11	Question: 5	QP Page: 31	MS Page: 51
0625_s20_qp_12	Question: 4	QP Page: 56	MS Page: 76
0625_s20_qp_12	Question: 5	QP Page: 56	MS Page: 76
0625_s20_qp_13	Question: 4	QP Page: 81	MS Page: 101
0625_s20_qp_13	Question: 5	QP Page: 81	MS Page: 101
0625_w20_qp_11	Question: 4	QP Page: 106	MS Page: 122
0625_w20_qp_12	Question: 4	QP Page: 127	MS Page: 143
0625_w20_qp_12	Question: 5	QP Page: 127	MS Page: 143
0625_w20_qp_13	Question: 4	QP Page: 148	MS Page: 164
0625_w20_qp_13	Question: 5	QP Page: 148	MS Page: 164

A.1.4 Density

0625_m20_qp_12	Question: 6	QP Page: 6	MS Page: 26
0625_s20_qp_11	Question: 6	QP Page: 32	MS Page: 51
0625_s20_qp_12	Question: 6	QP Page: 57	MS Page: 76
0625_s20_qp_13	Question: 6	QP Page: 82	MS Page: 101
0625_w20_qp_11	Question: 6	QP Page: 107	MS Page: 122
0625_w20_qp_12	Question: 6	QP Page: 127	MS Page: 143

0625_w20_qp_13 Question: 6 QP Page: 148 MS Page: 164

A.1.5 Forces

0625_m20_qp_12 Question: 7 QP Page: 7 MS Page: 26
0625_m20_qp_12 Question: 8 QP Page: 7 MS Page: 26
0625_s20_qp_11 Question: 7 QP Page: 32 MS Page: 51
0625_s20_qp_11 Question: 8 QP Page: 32 MS Page: 51
0625_s20_qp_12 Question: 7 QP Page: 57 MS Page: 76
0625_s20_qp_12 Question: 8 QP Page: 58 MS Page: 76
0625_s20_qp_13 Question: 7 QP Page: 82 MS Page: 101
0625_s20_qp_13 Question: 8 QP Page: 82 MS Page: 101
0625_s20_qp_13 Question: 9 QP Page: 83 MS Page: 101
0625_w20_qp_11 Question: 7 QP Page: 107 MS Page: 122
0625_w20_qp_11 Question: 8 QP Page: 108 MS Page: 122
0625_w20_qp_12 Question: 7 QP Page: 128 MS Page: 143
0625_w20_qp_12 Question: 8 QP Page: 128 MS Page: 143
0625_w20_qp_13 Question: 7 QP Page: 149 MS Page: 164
0625_w20_qp_13 Question: 8 QP Page: 149 MS Page: 164
0625_w20_qp_13 Question: 9 QP Page: 150 MS Page: 164

A.1.6 Energy, work and power

0625_m20_qp_12 Question: 9 QP Page: 7 MS Page: 26
0625_m20_qp_12 Question: 10 QP Page: 8 MS Page: 26
0625_m20_qp_12 Question: 11 QP Page: 8 MS Page: 26
0625_s20_qp_11 Question: 9 QP Page: 33 MS Page: 51
0625_s20_qp_11 Question: 10 QP Page: 33 MS Page: 51
0625_s20_qp_11 Question: 11 QP Page: 34 MS Page: 51
0625_s20_qp_12 Question: 9 QP Page: 58 MS Page: 76
0625_s20_qp_12 Question: 10 QP Page: 58 MS Page: 76
0625_s20_qp_12 Question: 11 QP Page: 59 MS Page: 76
0625_s20_qp_13 Question: 10 QP Page: 83 MS Page: 101
0625_s20_qp_13 Question: 11 QP Page: 84 MS Page: 101
0625_w20_qp_11 Question: 9 QP Page: 108 MS Page: 122
0625_w20_qp_11 Question: 10 QP Page: 108 MS Page: 122
0625_w20_qp_11 Question: 11 QP Page: 108 MS Page: 122
0625_w20_qp_12 Question: 9 QP Page: 128 MS Page: 143
0625_w20_qp_12 Question: 10 QP Page: 129 MS Page: 143
0625_w20_qp_12 Question: 11 QP Page: 129 MS Page: 143
0625_w20_qp_13 Question: 10 QP Page: 150 MS Page: 164
0625_w20_qp_13 Question: 11 QP Page: 150 MS Page: 164

A.1.7 Pressure

0625_m20_qp_12 Question: 12 QP Page: 9 MS Page: 26
0625_m20_qp_12 Question: 13 QP Page: 10 MS Page: 26
0625_s20_qp_11 Question: 12 QP Page: 35 MS Page: 51
0625_s20_qp_11 Question: 13 QP Page: 36 MS Page: 51
0625_s20_qp_12 Question: 12 QP Page: 60 MS Page: 76
0625_s20_qp_12 Question: 13 QP Page: 60 MS Page: 76
0625_s20_qp_13 Question: 12 QP Page: 85 MS Page: 101
0625_s20_qp_13 Question: 13 QP Page: 85 MS Page: 101
0625_w20_qp_11 Question: 12 QP Page: 109 MS Page: 122

0625_w20_qp_11	Question: 13	QP Page: 109	MS Page: 122
0625_w20_qp_12	Question: 12	QP Page: 129	MS Page: 143
0625_w20_qp_12	Question: 13	QP Page: 130	MS Page: 143
0625_w20_qp_13	Question: 12	QP Page: 151	MS Page: 164
0625_w20_qp_13	Question: 13	QP Page: 151	MS Page: 164

A.2 Thermal physics

A.2.1 Kinetic particle model of matter

0625_m20_qp_12	Question: 14	QP Page: 10	MS Page: 26
0625_s20_qp_11	Question: 14	QP Page: 36	MS Page: 51
0625_s20_qp_12	Question: 14	QP Page: 60	MS Page: 76
0625_s20_qp_12	Question: 15	QP Page: 61	MS Page: 76
0625_s20_qp_13	Question: 14	QP Page: 86	MS Page: 101
0625_s20_qp_13	Question: 15	QP Page: 86	MS Page: 101
0625_w20_qp_11	Question: 14	QP Page: 109	MS Page: 122
0625_w20_qp_12	Question: 14	QP Page: 130	MS Page: 143
0625_w20_qp_12	Question: 15	QP Page: 130	MS Page: 143
0625_w20_qp_13	Question: 14	QP Page: 151	MS Page: 164
0625_w20_qp_13	Question: 15	QP Page: 152	MS Page: 164

A.2.2 Thermal properties and temperature

0625_m20_qp_12	Question: 15	QP Page: 10	MS Page: 26
0625_m20_qp_12	Question: 16	QP Page: 11	MS Page: 26
0625_m20_qp_12	Question: 17	QP Page: 11	MS Page: 26
0625_m20_qp_12	Question: 18	QP Page: 11	MS Page: 26
0625_s20_qp_11	Question: 15	QP Page: 37	MS Page: 51
0625_s20_qp_11	Question: 16	QP Page: 37	MS Page: 51
0625_s20_qp_11	Question: 17	QP Page: 38	MS Page: 51
0625_s20_qp_11	Question: 18	QP Page: 38	MS Page: 51
0625_s20_qp_12	Question: 16	QP Page: 61	MS Page: 76
0625_s20_qp_12	Question: 17	QP Page: 61	MS Page: 76
0625_s20_qp_12	Question: 18	QP Page: 61	MS Page: 76
0625_s20_qp_13	Question: 16	QP Page: 86	MS Page: 101
0625_s20_qp_13	Question: 17	QP Page: 87	MS Page: 101
0625_s20_qp_13	Question: 18	QP Page: 87	MS Page: 101
0625_w20_qp_11	Question: 15	QP Page: 110	MS Page: 122
0625_w20_qp_11	Question: 16	QP Page: 110	MS Page: 122
0625_w20_qp_11	Question: 17	QP Page: 110	MS Page: 122
0625_w20_qp_12	Question: 16	QP Page: 131	MS Page: 143
0625_w20_qp_12	Question: 17	QP Page: 131	MS Page: 143
0625_w20_qp_13	Question: 16	QP Page: 152	MS Page: 164
0625_w20_qp_13	Question: 17	QP Page: 152	MS Page: 164

A.2.3 Transfer of thermal energy

0625_m20_qp_12	Question: 19	QP Page: 12	MS Page: 26
0625_m20_qp_12	Question: 20	QP Page: 12	MS Page: 26
0625_s20_qp_11	Question: 19	QP Page: 38	MS Page: 51
0625_s20_qp_11	Question: 20	QP Page: 39	MS Page: 51
0625_s20_qp_12	Question: 19	QP Page: 62	MS Page: 76
0625_s20_qp_12	Question: 20	QP Page: 62	MS Page: 76
0625_s20_qp_13	Question: 19	QP Page: 87	MS Page: 101

0625_s20_qp_13	Question: 20	QP Page: 88	MS Page: 101
0625_w20_qp_11	Question: 5	QP Page: 106	MS Page: 122
0625_w20_qp_11	Question: 18	QP Page: 111	MS Page: 122
0625_w20_qp_11	Question: 19	QP Page: 111	MS Page: 122
0625_w20_qp_12	Question: 18	QP Page: 131	MS Page: 143
0625_w20_qp_12	Question: 19	QP Page: 132	MS Page: 143
0625_w20_qp_13	Question: 18	QP Page: 153	MS Page: 164
0625_w20_qp_13	Question: 19	QP Page: 153	MS Page: 164

A.3 Waves

A.3.1 General properties of waves

0625_m20_qp_12	Question: 21	QP Page: 13	MS Page: 26
0625_m20_qp_12	Question: 22	QP Page: 14	MS Page: 26
0625_s20_qp_11	Question: 21	QP Page: 39	MS Page: 51
0625_s20_qp_11	Question: 22	QP Page: 40	MS Page: 51
0625_s20_qp_12	Question: 21	QP Page: 63	MS Page: 76
0625_s20_qp_12	Question: 22	QP Page: 63	MS Page: 76
0625_s20_qp_13	Question: 21	QP Page: 88	MS Page: 101
0625_s20_qp_13	Question: 22	QP Page: 89	MS Page: 101
0625_w20_qp_11	Question: 21	QP Page: 112	MS Page: 122
0625_w20_qp_12	Question: 20	QP Page: 132	MS Page: 143
0625_w20_qp_12	Question: 21	QP Page: 132	MS Page: 143
0625_w20_qp_13	Question: 20	QP Page: 153	MS Page: 164
0625_w20_qp_13	Question: 21	QP Page: 154	MS Page: 164

A.3.2 Light

0625_m20_qp_12	Question: 23	QP Page: 15	MS Page: 26
0625_m20_qp_12	Question: 24	QP Page: 16	MS Page: 26
0625_s20_qp_11	Question: 23	QP Page: 40	MS Page: 51
0625_s20_qp_11	Question: 24	QP Page: 41	MS Page: 51
0625_s20_qp_12	Question: 23	QP Page: 64	MS Page: 76
0625_s20_qp_12	Question: 24	QP Page: 64	MS Page: 76
0625_s20_qp_13	Question: 23	QP Page: 89	MS Page: 101
0625_s20_qp_13	Question: 24	QP Page: 89	MS Page: 101
0625_w20_qp_11	Question: 20	QP Page: 112	MS Page: 122
0625_w20_qp_11	Question: 22	QP Page: 113	MS Page: 122
0625_w20_qp_11	Question: 23	QP Page: 113	MS Page: 122
0625_w20_qp_11	Question: 24	QP Page: 114	MS Page: 122
0625_w20_qp_12	Question: 22	QP Page: 133	MS Page: 143
0625_w20_qp_12	Question: 23	QP Page: 133	MS Page: 143
0625_w20_qp_12	Question: 24	QP Page: 134	MS Page: 143
0625_w20_qp_13	Question: 22	QP Page: 154	MS Page: 164
0625_w20_qp_13	Question: 23	QP Page: 155	MS Page: 164
0625_w20_qp_13	Question: 24	QP Page: 155	MS Page: 164

A.3.3 Electromagnetic spectrum

0625_s20_qp_11	Question: 25	QP Page: 41	MS Page: 51
0625_s20_qp_12	Question: 25	QP Page: 65	MS Page: 76
0625_s20_qp_13	Question: 25	QP Page: 90	MS Page: 101
0625_w20_qp_11	Question: 25	QP Page: 114	MS Page: 122
0625_w20_qp_12	Question: 25	QP Page: 134	MS Page: 143

0625_w20_qp_13 Question: 25 QP Page: 156 MS Page: 164

A.3.4 Sound

0625_m20_qp_12 Question: 25 QP Page: 16 MS Page: 26
0625_m20_qp_12 Question: 26 QP Page: 16 MS Page: 26
0625_s20_qp_12 Question: 26 QP Page: 65 MS Page: 76
0625_s20_qp_13 Question: 26 QP Page: 90 MS Page: 101
0625_w20_qp_11 Question: 26 QP Page: 114 MS Page: 122
0625_w20_qp_12 Question: 26 QP Page: 134 MS Page: 143
0625_w20_qp_13 Question: 26 QP Page: 156 MS Page: 164

A.4 Electricity and magnetism

A.4.1 Simple phenomena of magnetism

0625_m20_qp_12 Question: 27 QP Page: 16 MS Page: 26
0625_m20_qp_12 Question: 28 QP Page: 17 MS Page: 26
0625_s20_qp_11 Question: 27 QP Page: 42 MS Page: 51
0625_s20_qp_11 Question: 28 QP Page: 43 MS Page: 51
0625_s20_qp_12 Question: 27 QP Page: 65 MS Page: 76
0625_s20_qp_12 Question: 28 QP Page: 66 MS Page: 76
0625_s20_qp_13 Question: 27 QP Page: 90 MS Page: 101
0625_s20_qp_13 Question: 28 QP Page: 91 MS Page: 101
0625_w20_qp_11 Question: 27 QP Page: 115 MS Page: 122
0625_w20_qp_11 Question: 28 QP Page: 115 MS Page: 122
0625_w20_qp_12 Question: 27 QP Page: 134 MS Page: 143
0625_w20_qp_12 Question: 28 QP Page: 135 MS Page: 143
0625_w20_qp_13 Question: 27 QP Page: 157 MS Page: 164
0625_w20_qp_13 Question: 28 QP Page: 157 MS Page: 164

A.4.2 Electrical quantities

0625_m20_qp_12 Question: 29 QP Page: 17 MS Page: 26
0625_m20_qp_12 Question: 30 QP Page: 18 MS Page: 26
0625_s20_qp_11 Question: 29 QP Page: 43 MS Page: 51
0625_s20_qp_11 Question: 30 QP Page: 44 MS Page: 51
0625_s20_qp_12 Question: 29 QP Page: 66 MS Page: 76
0625_s20_qp_13 Question: 29 QP Page: 91 MS Page: 101
0625_s20_qp_13 Question: 30 QP Page: 92 MS Page: 101
0625_w20_qp_11 Question: 29 QP Page: 115 MS Page: 122
0625_w20_qp_11 Question: 30 QP Page: 116 MS Page: 122
0625_w20_qp_12 Question: 29 QP Page: 135 MS Page: 143
0625_w20_qp_12 Question: 30 QP Page: 135 MS Page: 143
0625_w20_qp_13 Question: 29 QP Page: 158 MS Page: 164
0625_w20_qp_13 Question: 30 QP Page: 158 MS Page: 164

A.4.3 Electric circuits

0625_m20_qp_12 Question: 31 QP Page: 18 MS Page: 26
0625_m20_qp_12 Question: 32 QP Page: 19 MS Page: 26
0625_m20_qp_12 Question: 33 QP Page: 19 MS Page: 26
0625_m20_qp_12 Question: 34 QP Page: 20 MS Page: 26
0625_s20_qp_11 Question: 31 QP Page: 44 MS Page: 51

0625_s20_qp_11	Question: 32	QP Page: 45	MS Page: 51
0625_s20_qp_11	Question: 33	QP Page: 45	MS Page: 51
0625_s20_qp_12	Question: 30	QP Page: 67	MS Page: 76
0625_s20_qp_12	Question: 31	QP Page: 67	MS Page: 76
0625_s20_qp_12	Question: 32	QP Page: 68	MS Page: 76
0625_s20_qp_13	Question: 31	QP Page: 92	MS Page: 101
0625_s20_qp_13	Question: 32	QP Page: 92	MS Page: 101
0625_s20_qp_13	Question: 33	QP Page: 93	MS Page: 101
0625_s20_qp_13	Question: 34	QP Page: 93	MS Page: 101
0625_s20_qp_13	Question: 35	QP Page: 94	MS Page: 101
0625_w20_qp_11	Question: 31	QP Page: 116	MS Page: 122
0625_w20_qp_11	Question: 32	QP Page: 116	MS Page: 122
0625_w20_qp_12	Question: 31	QP Page: 136	MS Page: 143
0625_w20_qp_12	Question: 32	QP Page: 136	MS Page: 143
0625_w20_qp_13	Question: 31	QP Page: 158	MS Page: 164
0625_w20_qp_13	Question: 32	QP Page: 159	MS Page: 164

A.4.4 Electrical safety

0625_m20_qp_12	Question: 35	QP Page: 20	MS Page: 26
0625_s20_qp_11	Question: 26	QP Page: 42	MS Page: 51
0625_s20_qp_11	Question: 34	QP Page: 46	MS Page: 51
0625_s20_qp_12	Question: 33	QP Page: 68	MS Page: 76
0625_s20_qp_12	Question: 34	QP Page: 69	MS Page: 76
0625_w20_qp_11	Question: 33	QP Page: 117	MS Page: 122
0625_w20_qp_12	Question: 33	QP Page: 136	MS Page: 143
0625_w20_qp_13	Question: 33	QP Page: 159	MS Page: 164

A.4.5 Electromagnetic effects

0625_m20_qp_12	Question: 36	QP Page: 20	MS Page: 26
0625_m20_qp_12	Question: 37	QP Page: 21	MS Page: 26
0625_s20_qp_11	Question: 35	QP Page: 46	MS Page: 51
0625_s20_qp_11	Question: 36	QP Page: 47	MS Page: 51
0625_s20_qp_12	Question: 35	QP Page: 69	MS Page: 76
0625_s20_qp_12	Question: 36	QP Page: 70	MS Page: 76
0625_s20_qp_13	Question: 36	QP Page: 94	MS Page: 101
0625_w20_qp_11	Question: 34	QP Page: 117	MS Page: 122
0625_w20_qp_11	Question: 35	QP Page: 117	MS Page: 122
0625_w20_qp_11	Question: 36	QP Page: 118	MS Page: 122
0625_w20_qp_12	Question: 34	QP Page: 137	MS Page: 143
0625_w20_qp_12	Question: 35	QP Page: 137	MS Page: 143
0625_w20_qp_12	Question: 36	QP Page: 138	MS Page: 143
0625_w20_qp_13	Question: 34	QP Page: 159	MS Page: 164
0625_w20_qp_13	Question: 35	QP Page: 159	MS Page: 164
0625_w20_qp_13	Question: 36	QP Page: 160	MS Page: 164

A.5 Nuclear physics

A.5.1 The nuclear model of the atom

0625_m20_qp_12	Question: 38	QP Page: 21	MS Page: 26
0625_s20_qp_11	Question: 37	QP Page: 47	MS Page: 51
0625_s20_qp_11	Question: 38	QP Page: 47	MS Page: 51
0625_s20_qp_12	Question: 37	QP Page: 70	MS Page: 76

0625_s20_qp_12	Question: 38	QP Page: 70	MS Page: 76
0625_s20_qp_13	Question: 37	QP Page: 95	MS Page: 101
0625_s20_qp_13	Question: 38	QP Page: 95	MS Page: 101
0625_w20_qp_11	Question: 37	QP Page: 118	MS Page: 122
0625_w20_qp_11	Question: 38	QP Page: 118	MS Page: 122
0625_w20_qp_12	Question: 37	QP Page: 138	MS Page: 143
0625_w20_qp_12	Question: 38	QP Page: 138	MS Page: 143
0625_w20_qp_13	Question: 37	QP Page: 160	MS Page: 164
0625_w20_qp_13	Question: 38	QP Page: 160	MS Page: 164

A.5.2 Radioactivity

0625_m20_qp_12	Question: 39	QP Page: 22	MS Page: 26
0625_m20_qp_12	Question: 40	QP Page: 23	MS Page: 26
0625_s20_qp_11	Question: 39	QP Page: 48	MS Page: 51
0625_s20_qp_11	Question: 40	QP Page: 48	MS Page: 51
0625_s20_qp_12	Question: 39	QP Page: 71	MS Page: 76
0625_s20_qp_12	Question: 40	QP Page: 71	MS Page: 76
0625_s20_qp_13	Question: 39	QP Page: 96	MS Page: 101
0625_s20_qp_13	Question: 40	QP Page: 96	MS Page: 101
0625_w20_qp_11	Question: 39	QP Page: 119	MS Page: 122
0625_w20_qp_11	Question: 40	QP Page: 119	MS Page: 122
0625_w20_qp_12	Question: 39	QP Page: 139	MS Page: 143
0625_w20_qp_12	Question: 40	QP Page: 139	MS Page: 143
0625_w20_qp_13	Question: 39	QP Page: 161	MS Page: 164
0625_w20_qp_13	Question: 40	QP Page: 161	MS Page: 164